

GLOBAL SERIES
Air-Powered Double Diaphragm Pumps

G25 Aluminum

150 l/min Maximum Flow Rate

1 inch Port Size



The genesis of a new era is upon us! Specializing in pneumatically driven equipment for decades, we have combined genius technology with next generation manufacturing, enabling us to produce the latest genre of high quality pumps. The Global Series is now available worldwide for general industrial market applications.

Technical Specifications

Maximum Flow Rate	• 150 l/min
Port Size	• 1" Female Rc
Air Supply Pressure	• 2 - 7 Bar
Liquid Temperature	• 0 - 100 °C
Maximum Air Consumption	• 1400 NI/min
Weight	• 9,2 kg
Maximum Size Solid	• 3 mm (1/8")
Air Inlet	• 3/8" Female Rc
Body Material	• Aluminum (ADC-12)
Discharge Volume Per Cycle	• 600 ml
Dimensions	• L x W x H / 21,0cm x 25,5cm x 31,6cm



G25 Aluminum

150 l/min Maximum Flow Rate

1 inch Port Size

Features & Benefits

- Truly non-lubricated (no grease pre-pack) / maintenance free air distribution system
- Stall Free / Ice Free operation
- Fewer Wearing Parts
- Ease of Repair - Quick teardown / Rebuild
- 20% less air consumption over competitor's pumps
- Piping interchangeability with leading brands

Elastomeric Options

- Buna N
- Santoprene®
- Hytrel®
- Viton®

Stall-Free Operation

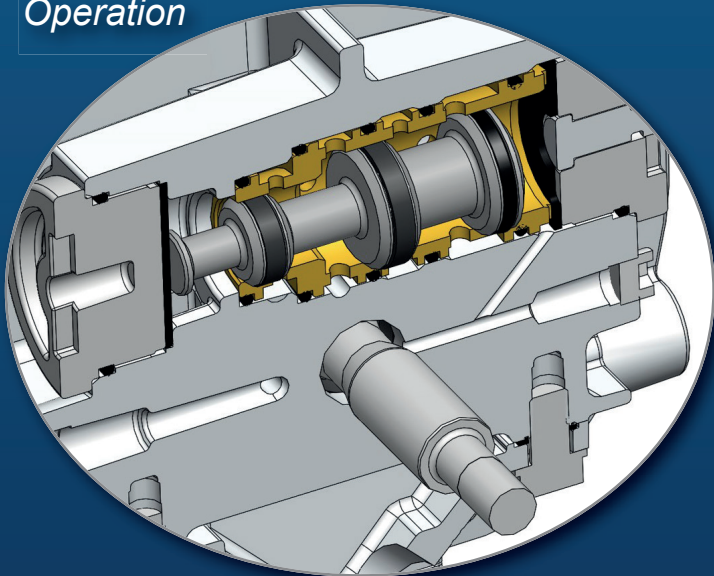

Rubber Diaphragms

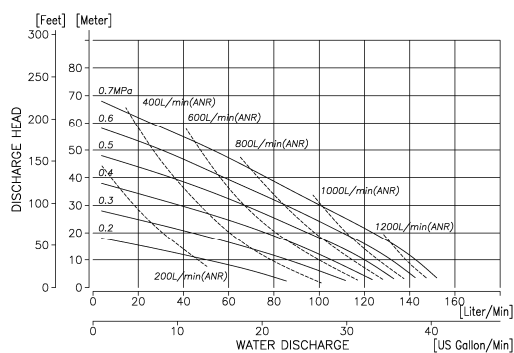

PTFE Diaphragms

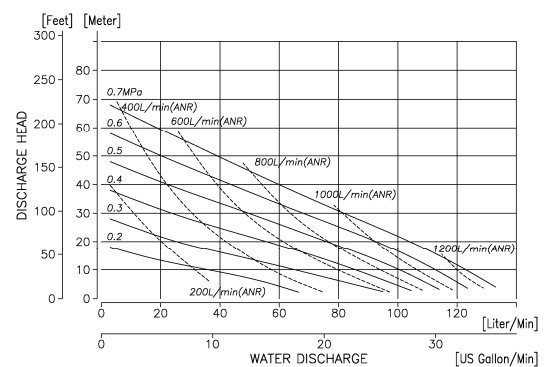

Yamada Europe B.V.



Aquamarijnstraat 50
7554 NS Hengelo (OV)
The Netherlands
Phone: +31 (0)74-242 2032
sales@yamada-europe.com
www.yamada-europe.com

Best is not good enough!