

EXPLODED VIEW & PARTS LISTING

Air Operated Double Diaphragm pump

Model : DP-10BP.

Yamada Europe B.V.



Material: PPG (Reinforced Polypropylene)

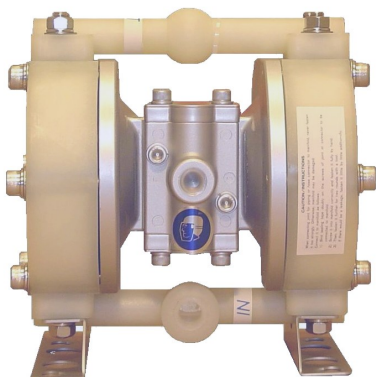

DP PUMPS REQUIRE A FRL UNIT TO LUBRICATE THE COMPRESSED AIR



To Purchase:

☎ 0031 (0)74 242 2032

✉ sales@yamada.nl

More information:

▶ YouTube: [@yamadapump](https://www.youtube.com/@yamadapump)

🌐 yamada-europe.com

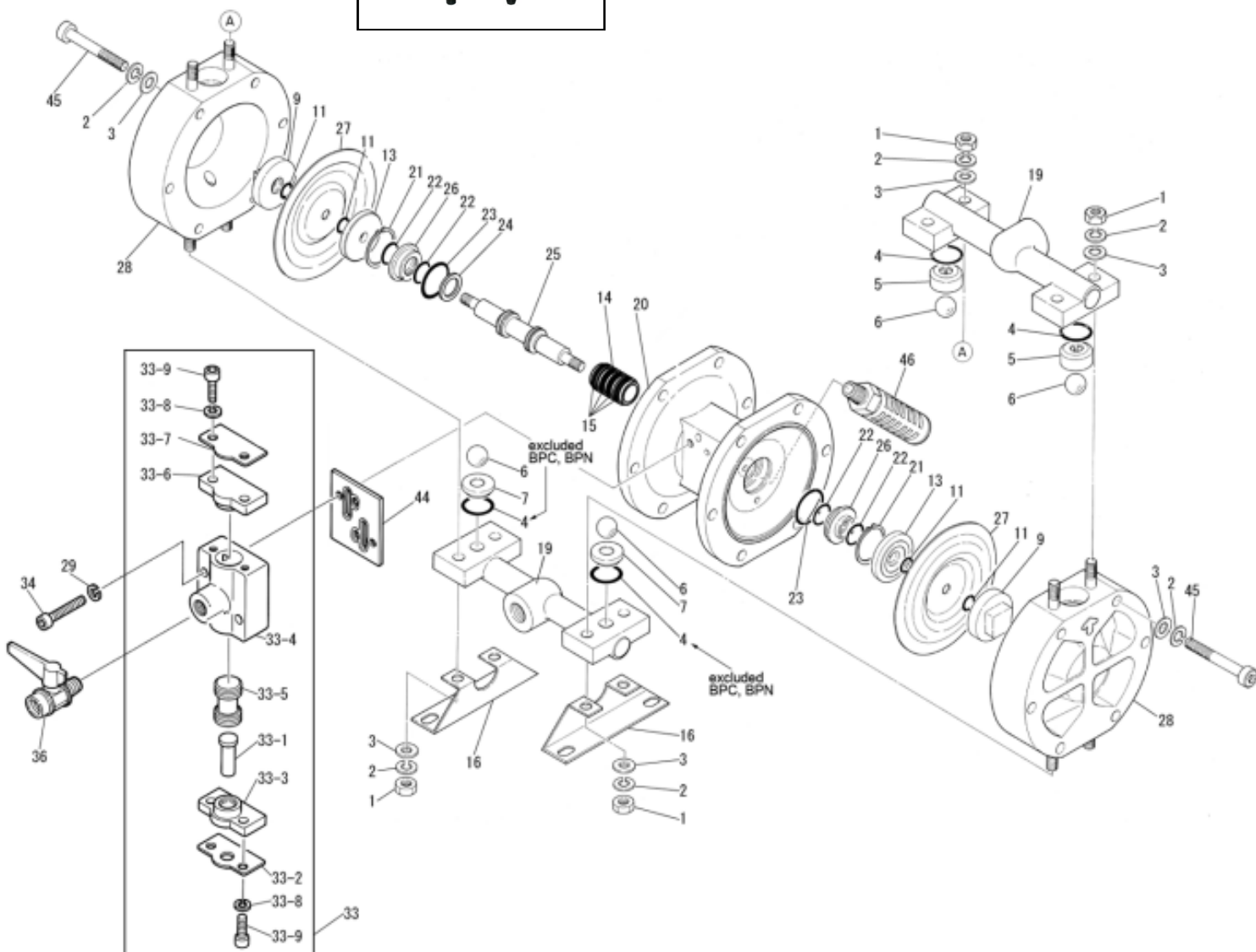

Tighting torque for:

Center rod: 14Nm
 Out chambers: 12Nm
 Manifolds: 8Nm

Special tools (sold seperately)

None

Miscellaneous:

Assembly oil: use turbine oil none additional class 1
 Equiv. to ISO VGA32 grade
 Use Urea grease grade NLGI No. 2

EXPLODED VIEW & PARTS LISTING

Air Operated Double Diaphragm pump

Model : DP-10BP.

Yamada Europe B.V.



Material: PPG (Reinforced Polypropylene)

DIAPHRAGM

Design

CR	NBR	EPDM	HYTREL	SANTOPRENE	PTFE
BPC	BPN	BNE	BPH	BPS	BPT
851745	852280	YE Original	851752	852676	851744

REF. No.	DESCRIPTION	Q'TY.	Part No.	Part No.	Part No.	Part No.	Part No.	Part No.
1	NUT	8	687229	687229	687229	687229	687229	687229
2	SPRING WASHER	20	681300	681300	681300	681300	681300	681300
3	PLAIN WASHER	20	631329	631329	631329	631329	631329	631329
4	O RING	2	640018	640018	—	—	—	—
		4	—	—	684112	640018	684112	643018
5	BALL GUIDE	2	771136	771136	771136	771136	771136	771136
6	BALL	4	770970	770972	771978	773124	773168	770931
7	VALVE SEAT	2	770975	770976	780270	780270	780270	780270
9	CENTER DISK	2	770968	770968	770968	770968	770968	770968
11	O RING	4	640005	640005	643005	—	—	643005
13	CENTER DISK	2	708770	708770	708770	708770	708770	708770
14	SLEEVE	1	714678	714678	714678	714678	714678	714678
15	O RING	4	684900	684900	684900	684900	684900	684900
16	BASE	2	708511	708511	708511	708511	708511	708511
19	MANIFOLD ASSY	2	831291	831291	831291	831291	831291	831291
20	BODY	1	715106	715106	715106	715106	715106	715106
21	RETAINING RING	2	630807	630807	630807	630807	630807	630807
22	PACKING	4	684284	684284	684284	684284	684284	684284
23	O RING	2	640131	640131	640131	640131	640131	640131
24	SPACER	1	772651	772651	772651	772651	772651	772651
25	CENTER ROD ASSY	1	801785	801785	801785	801785	801785	801785
26	GUIDE BUSHING	2	772619	772619	772619	772619	772619	772619
27	DIAPHRAGM	2	770971	770973	771848	771372	771972	770933
28	OUT CHAMBER	2	780194	780194	780194	780194	780194	780194
29	SPRING WASHER	2	681855	681855	681855	681855	681855	681855
33	VALVE BODY ASSY	1	804504	804504	804504	804504	804504	804504
33- 1	RESET BUTTON	1	706798	706798	706798	706798	706798	706798
33- 2	PLATE A	1	710587	710587	710587	710587	710587	710587
33- 3	SPOOL END COVER	1	771357	771357	771357	771357	771357	771357
33- 4	SPOOL CASE	1	710574	710574	710574	710574	710574	710574
33- 5	SPOOL ASSY	1	801404	801404	801404	801404	801404	801404
33- 6	SPOOL COVER	1	771356	771356	771356	771356	771356	771356
33- 7	PLATE B	1	710636	710636	710636	710636	710636	710636
33- 8	SPRING WASHER	4	681855	681855	681855	681855	681855	681855
33- 9	BOLT	4	682943	682943	682943	682943	682943	682943
34	BOLT	2	682918	682918	682918	682918	682918	682918
36	VALVE	1	686825	686825	686825	686825	686825	686825
44	GASKET	1	771358	771358	771358	771358	771358	771358
45	BOLT	12	682945	682945	682945	682945	682945	682945
46	MUFFLER	1	681293	681293	681293	681293	681293	681293
KIT	DIAPHRAGM		K10D-PC	K10D-PN	K10D-PE	K10D-PH	K10D-PS	K10D-PT
KIT	VALVE		K10V-PC	K10V-PN	K10V-PE	K10V-PH	K10V-PS	K10V-PT
KIT	WET END REPAIR		K10-PC	K10-PN	K10-PE	K10-PH	K10-PS	K10-PT
KIT	AIR MOTOR		K10-AM					
KIT	AIR MOTOR SEAL		K10-AMS					

EXPLODED VIEW & PARTS LISTING

Air Operated Double Diaphragm pump

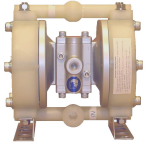

MODEL : DP-10P.

Model : DP-10BP.

Yamada Europe B.V.



Material: PPG (Reinforced Polypropylene)

Diaphragm options	CR, NBR, EPDM, TPEE, TPO,	PTFE
Max performance	20 L/min	17 L/min
Manifold connection	BSPT 3/8"	
Net Weight	3,1 kg	

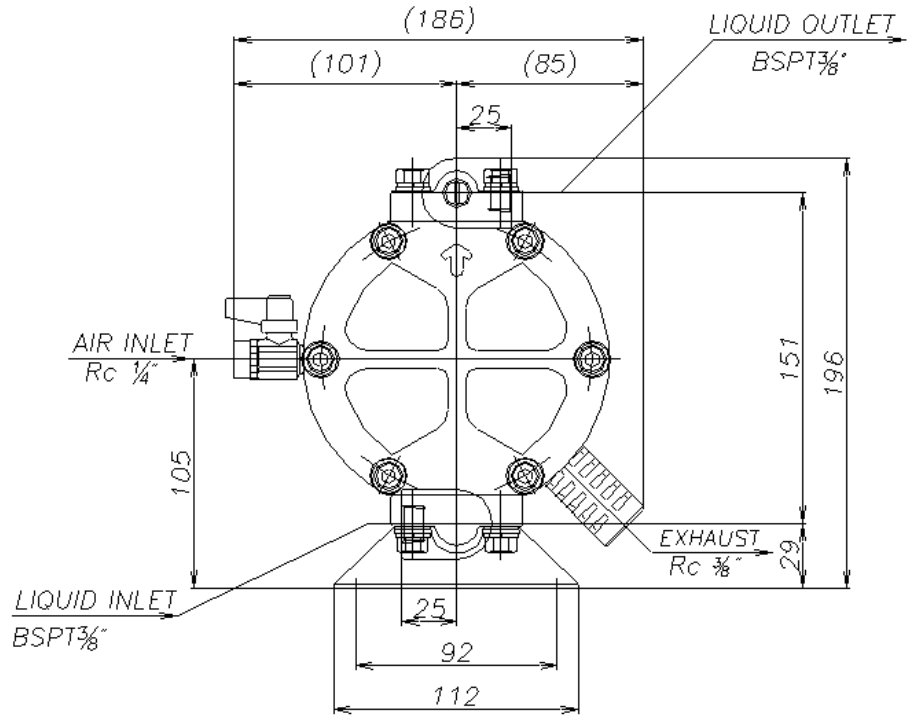
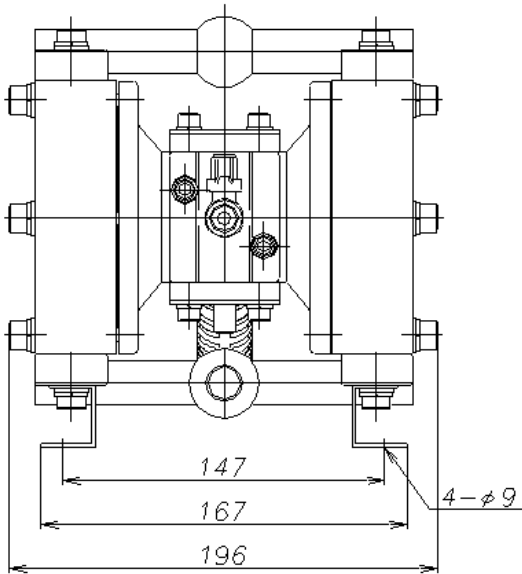

0,1MPa = 1Bar

