

EXPLODED VIEW & PARTS LISTING

Air Operated Double Diaphragm pump

Model : DP-10BS.

Yamada Europe B.V.



Material: Stainless steel 316 (SCS14)

DP PUMPS REQUIRE A FRL UNIT TO LUBRICATE THE COMPRESSED AIR



To Purchase:

☎ 0031 (0)74 242 2032

✉ sales@yamada.nl

More information:

▶ YouTube: [@yamadapump](https://www.youtube.com/@yamadapump)

🌐 yamada-europe.com

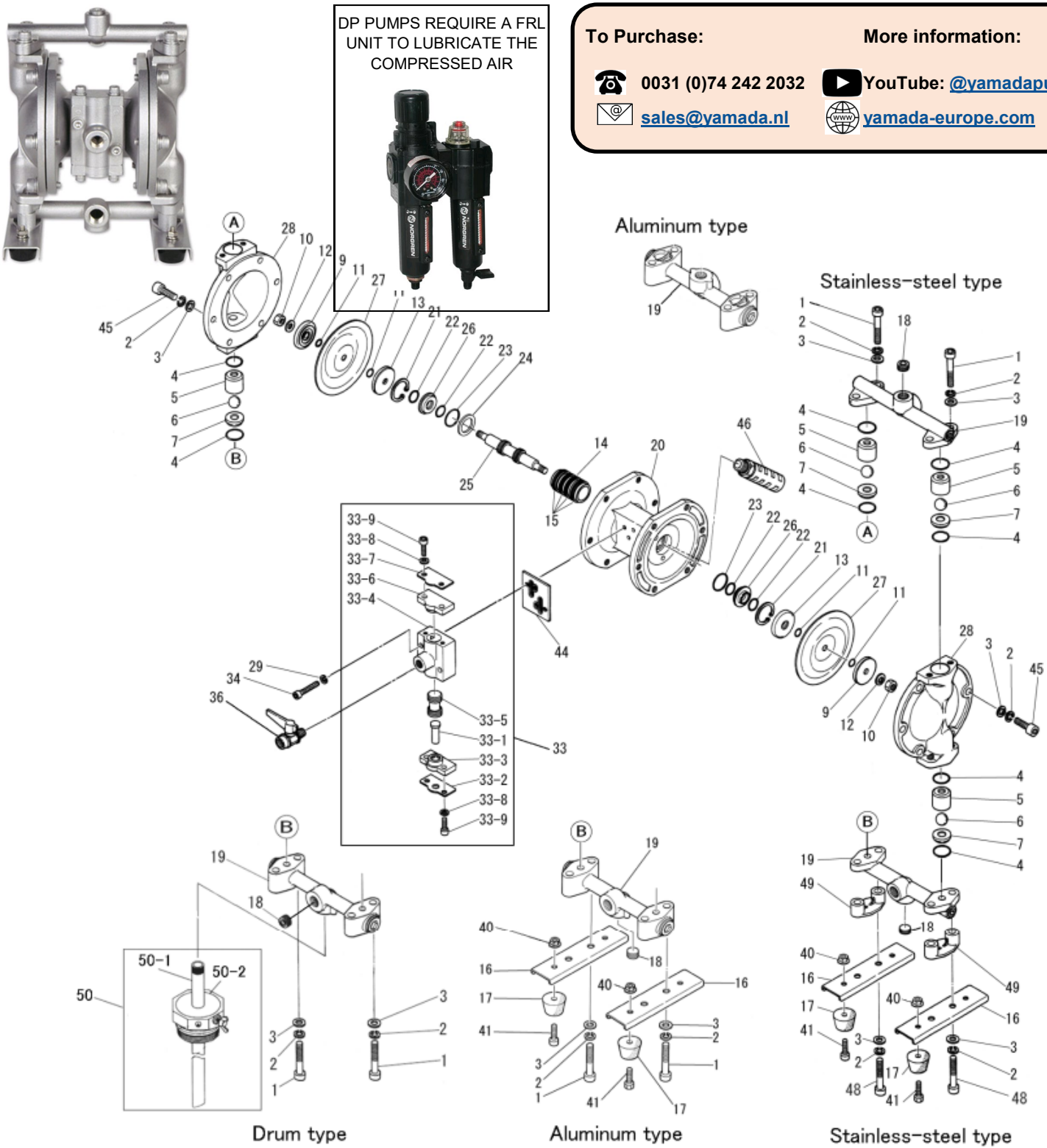

Tighting torque for:
 Center rod: 14Nm
 Out chambers: 12Nm
 Manifolds: 12Nm

Special tools (sold seperately)
 None

Miscellaneous:
 Assembly oil: use turbine oil none additional class 1
 Equiv. to ISO VGA32 grade
 Use Urea grease grade NLGI No. 2

EXPLODED VIEW & PARTS LISTING

Air Operated Double Diaphragm pump



DIAPHRAGM

Design #

Model : DP-10BS.

Yamada Europe B.V.



Material: Stainless steel 316 (SCS14)

REF. No.	DESCRIPTION	Q'TY.	Material						
			CR	NBR	EPDM	HYTREL	SANTOPRENE	PTFE	
			BSC	BSN	BSE	BSH	BSS	BST	
			851746	851747	YE Original	851751	852675	851741	
			Part No.	Part No.	Part No.	Part No.	Part No.	Part No.	
1	BOLT	4	681297	681297	681297	681297	681297	681297	
2	SPRING WASHER	20	681300	681300	681300	681300	681300	681300	
3	PLAIN WASHER	20	631329	631329	631329	631329	631329	631329	
4	O RING	8	640018	640018	684112	640018	684112	643018	
5	BALL GUIDE	4	710637	710637	710637	710637	710637	710637	
6	BALL	4	770970	770972	771978	773124	773168	770931	
7	VALVE SEAT	4	708913	708913	708913	708913	708913	708913	
9	CENTER DISK	2	708506	708506	708506	708506	708506	708506	
10	NUT	2	681849	681849	681849	681849	681849	681849	
11	O RING	4	640005	640005	643005	—	—	643005	
12	CONED DISC SPRING	2	684916	684916	684916	684916	684916	684916	
13	CENTER DISK	2	709512	709512	709512	709512	709512	709512	
14	SLEEVE	1	714678	714678	714678	714678	714678	714678	
15	O RING	4	684900	684900	684900	684900	684900	684900	
16	BASE	2	717184	717184	717184	717184	717184	717184	
17	RUBBER FOOT	4	771123	771123	771123	771123	771123	771123	
18	PLUG	2	709340	709340	709340	709340	709340	709340	
19	MANIFOLD ASSY	2	831529	831529	831529	831529	831529	831529	
20	BODY	1	715106	715106	715106	715106	715106	715106	
21	RETAINING RING	2	630807	630807	630807	630807	630807	630807	
22	PACKING	4	684284	684284	684284	684284	684284	684284	
23	O RING	2	640131	640131	640131	640131	640131	640131	
24	SPACER	1	772651	772651	772651	772651	772651	772651	
25	CENTER ROD ASSY	1	801785	801785	801785	801785	801785	801785	
26	GUIDE BUSHING	2	772619	772619	772619	772619	772619	772619	
27	DIAPHRAGM	2	770971	770973	771848	771372	771972	770933	
28	OUT CHAMBER	2	710660	710660	710660	710660	710660	710660	
29	SPRING WASHER	2	681855	681855	681855	681855	681855	681855	
33	VALVE BODY ASSY	1	804504	804504	804504	804504	804504	804504	
33- 1	RESET BUTTON	1	706798	706798	706798	706798	706798	706798	
33- 2	PLATE A	1	710587	710587	710587	710587	710587	710587	
33- 3	SPOOL END COVER	1	771357	771357	771357	771357	771357	771357	
33- 4	SPOOL CASE	1	710574	710574	710574	710574	710574	710574	
33- 5	SPOOL ASSY	1	801404	801404	801404	801404	801404	801404	
33- 6	SPOOL COVER	1	771356	771356	771356	771356	771356	771356	
33- 7	PLATE B	1	710636	710636	710636	710636	710636	710636	
33- 8	SPRING WASHER	4	681855	681855	681855	681855	681855	681855	
33- 9	BOLT	4	682943	682943	682943	682943	682943	682943	
34	BOLT	2	682918	682918	682918	682918	682918	682918	
36	VALVE	1	686825	686825	686825	686825	686825	686825	
40	FLANGED NUT	4	682817	682817	682817	682817	682817	682817	
41	BOLT	4	611101	611101	611101	611101	611101	611101	
44	GASKET	1	771358	771358	771358	771358	771358	771358	
45	BOLT	12	682944	682944	682944	682944	682944	682944	
46	MUFFLER	1	681293	681293	681293	681293	681293	681293	
48	BOLT	4	682971	682971	682971	682971	682971	682971	
49	COLLAR	2	771380	771380	771380	771380	771380	771380	
	KIT		DIAPHRAGM	K10D-MC	K10D-MN	K10D-ME	K10D-MH	K10D-MS	K10D-MT
	KIT		VALVE	K10V-SC	K10V-SN	K10V-SE	K10V-SH	K10V-SS	K10V-ST
	KIT		WET END REPAIR	K10-SC	K10-SN	K10-SE	K10-SH	K10-SS	K10-ST
	KIT		AIR MOTOR	K10-AM					
	KIT		AIR MOTOR SEAL	K10-AMS					

EXPLODED VIEW & PARTS LISTING

Air Operated Double Diaphragm pump



MODEL : DP-10BS.

Model : DP-10BS.

Yamada Europe B.V.



Material: Stainless steel 316 (SCS14)

Diaphragm options	CR, NBR, EPDM, TPEE, TPO, PTFE
Max performance	20 L/min
Manifold connection	BSPT 3/8"
Net Weight	5,2 kg

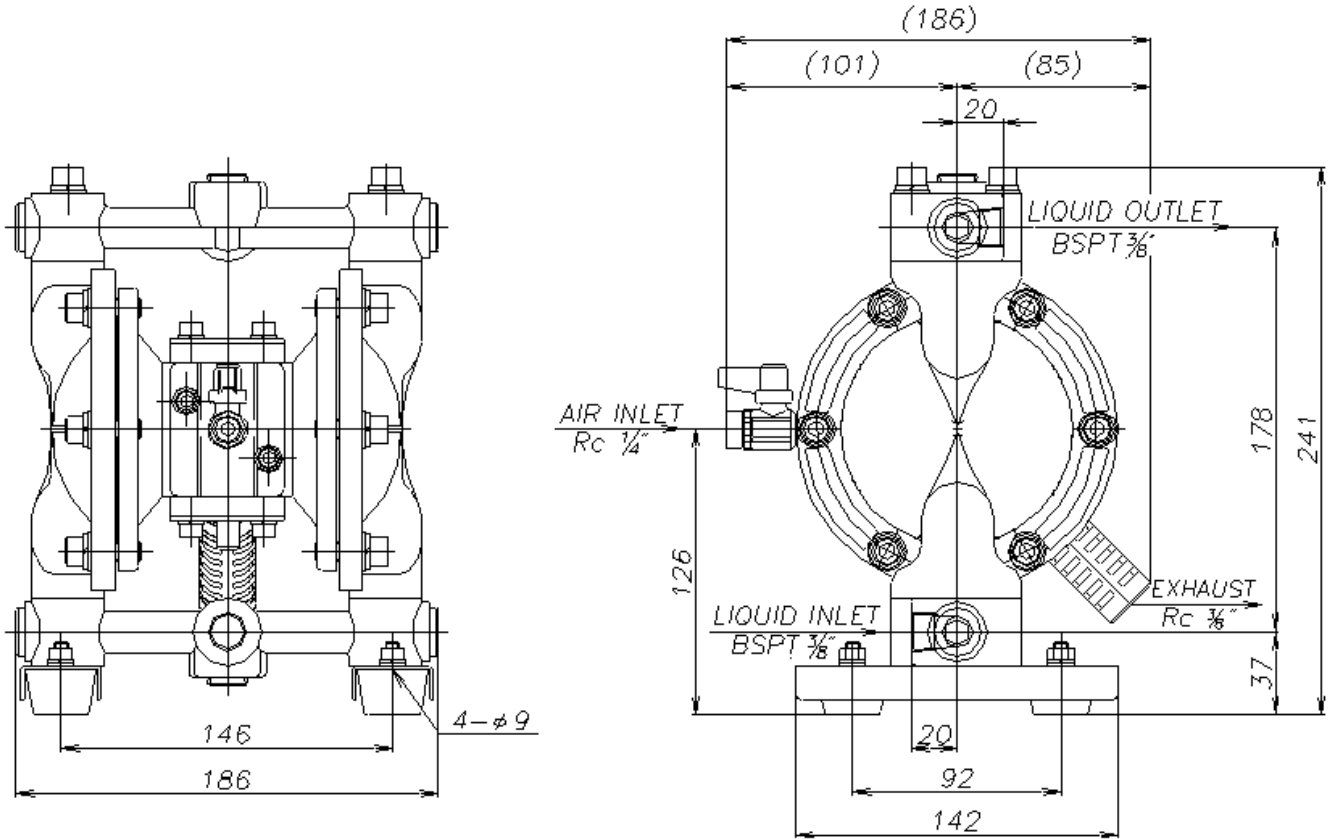

0,1MPa = 1Bar

