

EXPLODED VIEW & PARTS LISTING

Air Operated Double Diaphragm pump

Model : G15V.

Yamada Europe B.V.



Material: PVDF (Polyvinylidene fluoride virgin)

To Purchase:

More information:

☎ 0031 (0)74 242 2032

▶ YouTube: [@yamadapump](https://www.youtube.com/@yamadapump)

✉ sales@yamada.nl

🌐 yamada-europe.com

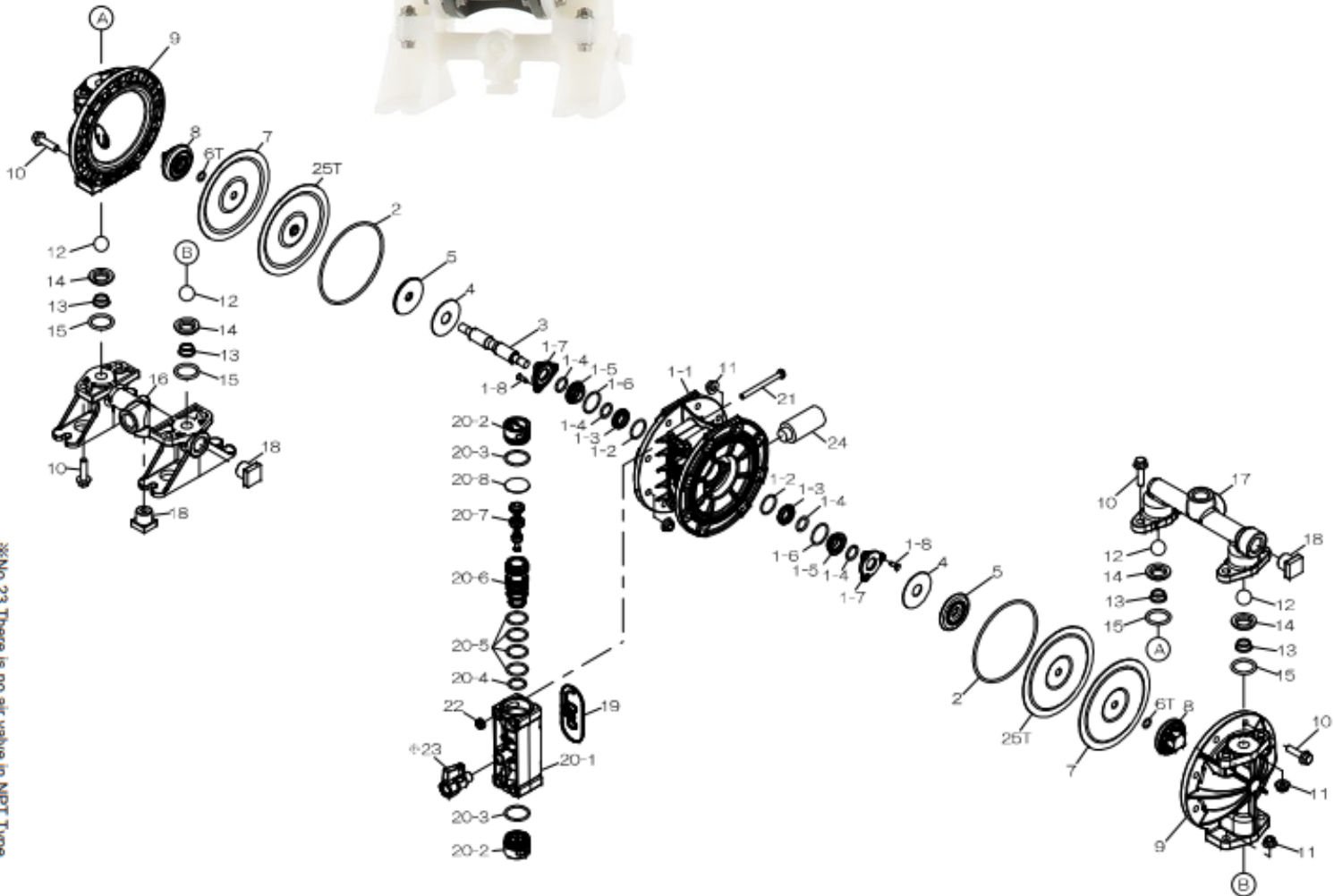
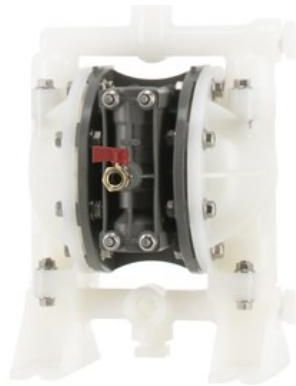

※No.23 There is no air valve in NPT Type

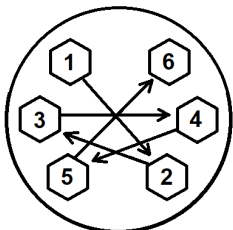
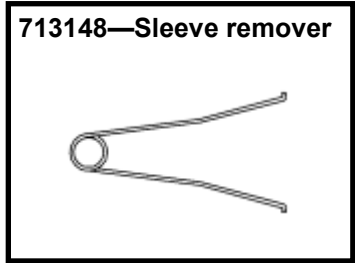

Tighting torque for:
 Center rod: 20 Nm
 Out chambers: 10 Nm
 Manifolds: 10 Nm

Special tools (sold seperately)
 713148 Sleeve remover

Miscellaneous:
 Assembly oil: use turbine oil none additional class 1
 Equiv. to ISO VGA32 grade
 Use Urea grease grade NLGI No. 2

EXPLODED VIEW & PARTS LISTING

Air Operated Double Diaphragm pump

Model : G15V.

Yamada Europe B.V.



Material: PVDF (Polyvinylidene fluoride virgin)



DIAPHRAGM

Design #

HYTREL	SANTOPRENE	PTFE
VH00	VS00	VT00
854984	854983	854982

REF. No.	DESCRIPTION	Q'TY.	Part No.	Part No.	Part No.
1	BODY ASSY	1	805207	805207	805207
1- 1	CENTER BODY	1	773380	773380	773380
1- 2	O RING	2	686893	686893	686893
1- 3	GUIDE BUSHING A	2	773385	773385	773385
1- 4	O RING	4	640015	640015	640015
1- 5	GUIDE BUSHING B	2	780301	780301	780301
1- 6	O RING	2	684900	684900	684900
1- 7	GUIDE BUSHING STOPPER	2	773384	773384	773384
1- 8	TAPPING SCREW	6	686894	686894	686894
2	O RING	2	640147	640147	640147
3	CENTER ROD	1	717100	717100	717100
4	CUSHION	2	773278	773278	773278
5	CENTER DISK	2	716923	716923	716923
6T	O RING	2	—	—	643007
7	DIAPHRAGM	2	773316	773315	773276
8	CENTER DISK	2	773400	773400	773400
9	OUT CHAMBER	2	780304	780304	780304
10	FLANGED BOLT	24	686892	686892	686892
11	FLANGED NUT	24	686032	686032	686032
12	BALL	4	773374	773424	773423
13	VALVE SEAT B	4	773432	773432	773432
14	VALVE SEAT A	4	773431	773431	773431
15	O RING	4	640025	684114	643025
16	MANIFOLD B	1	780308	780308	780308
17	MANIFOLD A	1	773403	773403	773403
18	PLUG	3	773401	773401	773401
19	GASKET	1	773407	773407	773407
20	VALVE BODY ASSY	1	805209	805209	805209
20- 1	VALVE BODY	1	833227	833227	833227
20- 2	CAP	2	773383	773383	773383
20- 3	O RING	2	683112	683112	683112
20- 4	O RING	1	685453	685453	685453
20- 5	O RING	4	685276	685276	685276
20- 6	SLEEVE	1	780302	780302	780302
20- 7	SPOOL ASSY	1	805208	805208	805208
20- 8	CUSHION	1	773428	773428	773428
21	BOLT	4	621115	621115	621115
22	FLANGED NUT	4	684086	684086	684086
23	VALVE	1	686825	686825	686825
24	MUFFLER	1	686757	686757	686757
25T	BACK UP DIAPHRAGM	2	—	—	773447
KIT	DIAPHRAGM		KG15D-PH	KG15D-PS	KG15D-PT
KIT	VALVE		KG15V-VH	KG15V-VS	KG15V-VT
KIT	WET END REPAIR		KG15-PH	KG15-PS	KG15-PT
KIT	AIR MOTOR			KG15P-AM	
KIT	AIR MOTOR SEAL			KG15P-AMS	

EXPLODED VIEW & PARTS LISTING

Air Operated Double Diaphragm pump



MODEL : G15P.

Model : G15V

Yamada Europe B.V.



Material: PVDF (Polyvinylidene fluoride virgin)

Diaphragm options	TPEE, TPO, PTFE
Max performance	62 L/min
Manifold connection	Rc 1/2"
Net Weight	3,5 kg

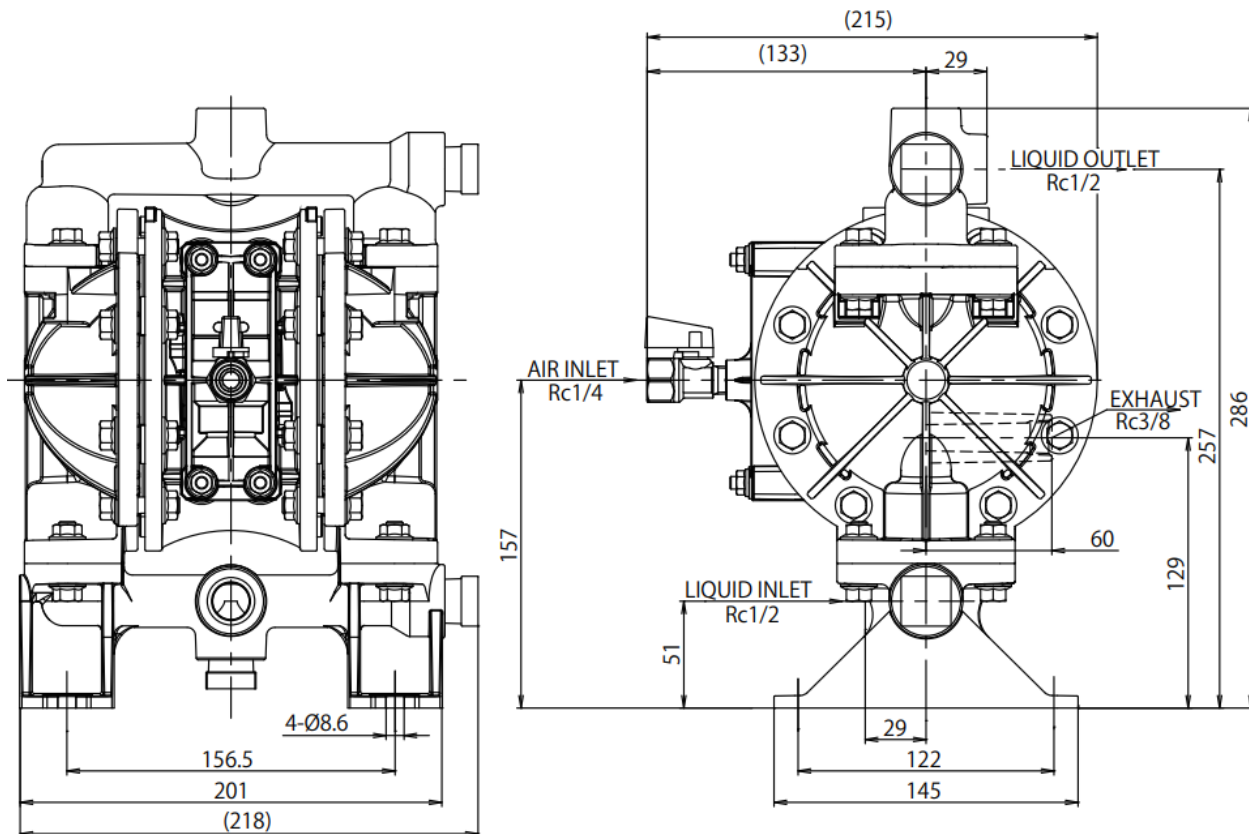

0,1MPa = 1Bar

■ G15P □, G15V □

