



# MAINTENANCE MANUAL

## YAMADA AIR-OPERATED DOUBLE DIAPHRAGM PUMP

NDP-5  
NDP-15

## WARNING



- For your own safety, be sure to read these procedures carefully before performing maintenance on this product. After reading this document, be sure to keep it handy for future reference.

This maintenance manual covers what you should know about maintenance of the Yamada NDP-5 series and NDP-15 series Diaphragm Pumps.

This edition is based on the standards for the November 2024 production run. Remember, the specifications are always subject to change; therefore, some of the information in this edition may not apply to new specifications.

### Warnings and Cautions

For safe use of this product, be sure to note the following: In this document, warnings and cautions are indicated by symbols. These symbols are for those who will operate this product and for those who will be nearby, for safe operation and for prevention of personal injury and property damage. The following warning and caution symbols have the meanings described below. Be sure to remember their meanings.



**WARNING:** If you ignore the warning described and operate the product in an improper manner, there is danger of serious bodily injury or death.



**CAUTION :** If you ignore the caution described and operate the product in an improper manner, there is danger of personal injury or property damage.

Furthermore, to indicate the type of danger and damage, the following symbols are also used along with those mentioned above:



This symbol indicates a DON'T, and will be accompanied by an explanation on something you must not do.



This symbol indicates a DO, and will be accompanied by instructions on something you must do in a certain situation.

## WARNING



- Before starting maintenance work, cut off the feed air and clean the pump. If air pressure or residue remain in the pump, there is danger of explosion, or possible poisoning resulting in serious injury or death if chemicals adhere to the skin or are accidentally swallowed. (For details on cleaning the pump, refer to Chapter 6 of the Operation Manual.)



- When replacing parts, be sure to use the recommended genuine parts or Equivalents. Use of other parts may cause a malfunction of the product. (Refer to Parts List the separate sheets.)

## CAUTION



- When it is instructed that special tools must be used, be sure to use the specified tools. Otherwise, the pump may be damaged.



- Refer to “10.1 Specifications” in the Operation Manual. Also, remember that the pump is heavy, and extreme care must be taken when lifting it.

# Table of Contents

·Warnings and Cautions	
·Table of Contents	
1.Principles of operation	1
2.Maintenance and Tools	
2.1 Maintenance	1
2.2 General tools	1
2.3 Special tools	1
2.4 Misc.	1
3.Ordering Replacement parts	1
4.Balls, Flat valves and Valve seats	
4.1 Removal	
■FAT, FST, BA□, BS□ types	2
■FP□, BPS, FV□, FDT types	3
4.2 Inspection	
■Ball valve types	4
■Flat valve types	4
4.3 Installation	4
5.Diaphragm and Center rod	
5.1 Removal	
■FAT, FST, BA□, BS□ types	5
■FP□, BPS, FV□, FDT types	6
5.2 Inspection	6
5.3 Installation	
■B□H, B□S, FPH, F□S types	7
■B□C, B□N, B□T, FPC, FPN, F□T types	7
6.Pilot valve Assembly, Guide and Bushing	
6.1 Removal	
■NDP-5	8
■NDP-15	8
6.2 Inspection	8
6.3 Installation	8
7.C spool valve Assembly and Sleeve Assembly	
7.1 Removal	9
7.2 Inspection	9
7.3 Installation	9
8.Retightening of Tie rods	10

## 1. Principles of operation

There are two diaphragms fixed to the center rod, one at each end. When compressed air is supplied to air chamber b (right side, see Fig.1.1), the center rod moves to the right, the material in material chamber B is pushed out, and at the same time material is sucked into material chamber A.

When the center rod is moved full-stroke to the right, the air switch valve is switched, compressed air is sent to air chamber a (left side, see Fig.1.2), and the center rod moves to the left. The material in material chamber A is pushed out, and at the same time material is sucked into material chamber B.

Through repetition of this operation, material is repeatedly taken in and discharged out.

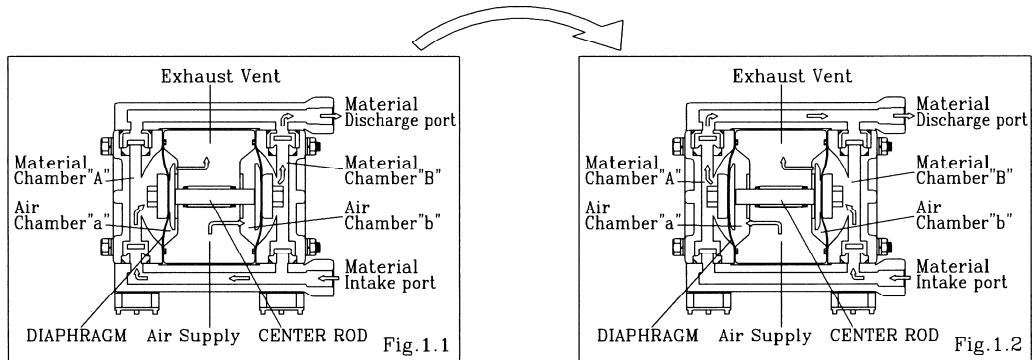

## 2. Maintenance and Tools

### 2.1 Maintenance

It is recommended that the pump should be regularly inspected, as this kind of diaphragm pump can be used in many different circumstances such as pressures, temperatures, viscosities, or corrosiveness.

It's very useful for your future reference to keep records of the pump conditions for every inspection.

The regular inspection includes the air valve, diaphragms, balls, valve seats, or O-rings.

When it comes to diaphragms, in particular, both of the diaphragms should be replaced at one time, as they tend to be worn out or have some cracks on the surfaces. Please refer to 'usage range' in each section regarding the frequency of the replacement of the other spare parts.

### 2.2 General tools

- Socket wrenches 10 mm(NDP-5), 13 mm(NDP-15)
- Open-end wrenches 10 mm(NDP-5), 13 mm(NDP-15), 21 mm(NDP-15)
- Plier

### 2.3 Special tools (sold separately)

- Cap and disk remover  
Purpose: Removing the center disk of NDP-5FPT, FVT, FDT types

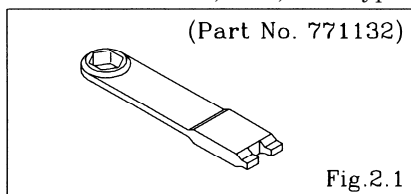

- Sleeve remover  
Purpose: For removing sleeves

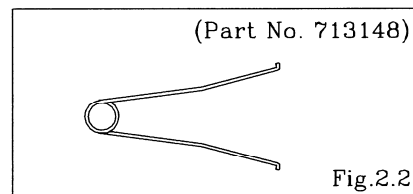

### 2.4 Misc.

- Assembly oil Turbine oil none addition class 1(equivalent to ISO VG32 grade)
- Nuts M6 x 1(NDP-5), M8 x 1.25(NDP-15)
- Grease Urea grease grade (NLGI) No.2

## 3. Ordering Replacement parts

For accurate and speedy shipment of parts, be sure to order the right parts for your model to distributor. Indicate the part numbers, descriptions, and quantities.

## 4. Balls, Flat valves and Valve seats

### 4.1 Removal

#### ■ FAT, FST, BA□, BS□ types

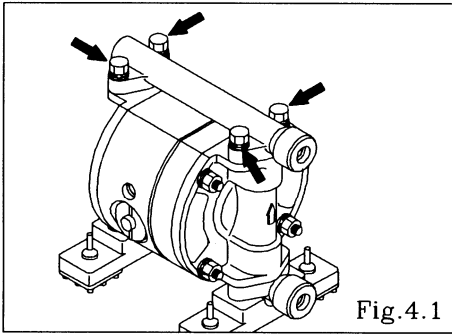

- Remove the 4 retainer bolts from the out manifold, and remove the out manifold. [Fig.4.1]

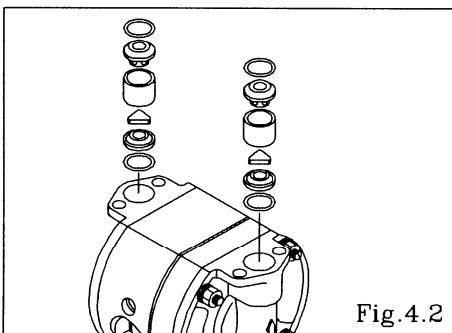

- Remove the O ring, valve stopper, valve guide, flat valve and valve seat. (NDP-5) [Fig.4.2]
- Remove the O ring, valve guide, ball and valve seat. (NDP-15) [Fig.4.2]

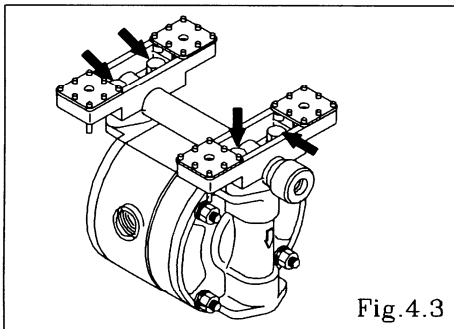

- Turn over the main body assembly. [Fig.4.3]
- Remove the 4 retainer bolts from the in manifold, and remove the base and in manifold. [Fig.4.3]

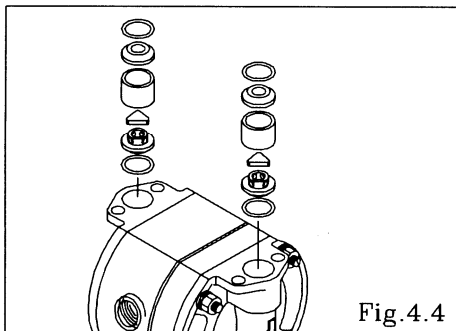

- Remove the O ring, valve seat, flat valve, valve guide and valve stopper. (NDP-5) [Fig.4.4]
- Remove the O ring, valve seat, ball and valve guide. (NDP-15) [Fig.4.4]

## ■FP□, BPS, FV□, FDT types

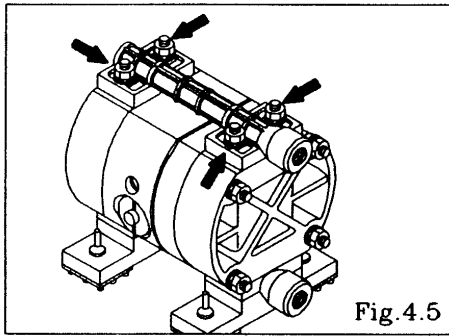

- Remove the 4 retainer nuts from the out manifold, and remove the out manifold. [Fig.4.5]

< NOTE >

- When the retainer nuts both side of the tie rod remove, the in manifold removes. (NDP-5)

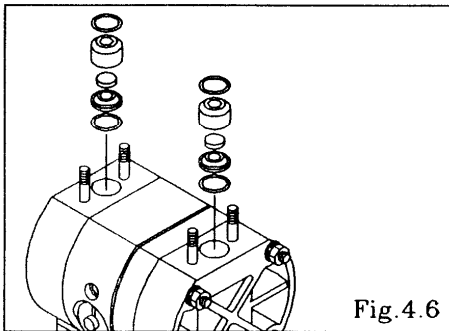

- Remove the O ring, valve stopper, flat valve and valve seat. [Fig.4.6]

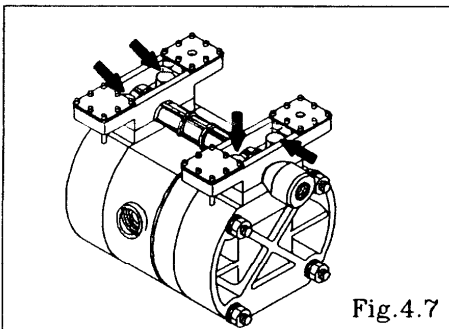

- Turn over the main body assembly. [Fig.4.7]
- Pull out the bolt, and remove the base and in manifold. (NDP-5)
- Remove the 4 retainer bolts from the in manifold, and remove the base and in manifold. (NDP-15) [Fig.4.7]

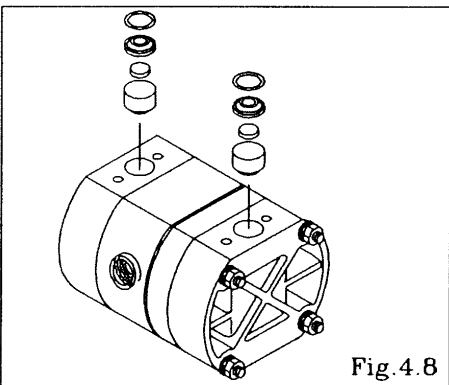

- Remove the O ring, valve seat, flat valve and valve stopper. [Fig.4.8]

## 4.2 Inspection

### ■ Ball valve type

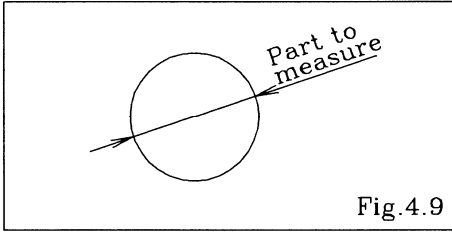

- Ball [Fig.4.9]  
Measure the outside diameter, and if it is outside the usable range, replace the ball.

Usable range of Ball	
NDP-15	Sø 20.0 - Sø 22.8 mm

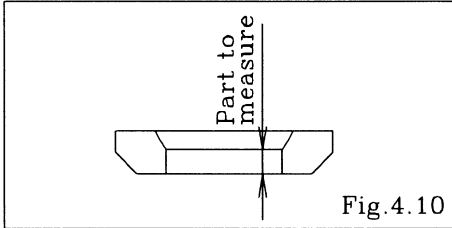

- Valve seat [Fig.4.10]  
Measure the dimension shown at left, and if it is outside the usable range, replace the seat.

Usable range of Valve seat	
NDP-15	2.6 - 5.7 mm

### ■ Flat valve type

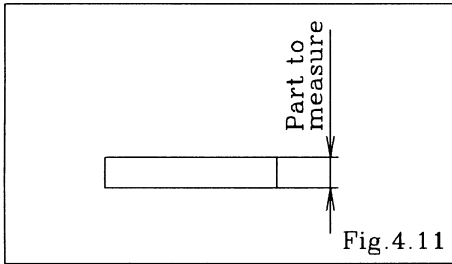

- Flat valve [Fig.4.11]  
Measure the dimension shown at left, and if it is outside the usable range, replace the seat. If the seal ring is worn out or cracked, replace it.

Usable range of Flat valve	
NDP-5	2.5 - 3.1 mm
NDP-15	4.3 - 5.0 mm

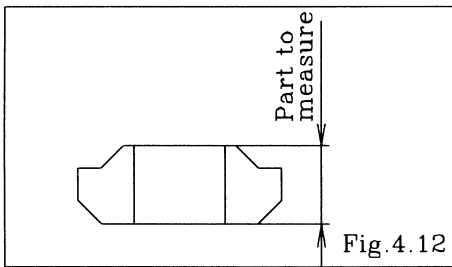

- Valve seat [Fig.4.12]  
Measure the dimension shown at left, and if it is outside the usable range, replace the seat.

Usable range of Valve seat	
NDP-5	5.8 - 7.1 mm
NDP-15	8.2 - 10.0 mm

- O ring (other than PTFE)  
If O ring is worn out or cracked, replace it.

## 4.3 Installation

For installation, see [Exploded View] on the separate sheet and install in the reverse order of disassembly.

Tightening torque for manifold retainer bolts or nuts	
NDP-5	6 N·m
NDP-15	12 N·m

< NOTE >

- Make sure there is no dust on the seal surface and the seal is not damaged.
- Replace the PTFE O ring regardless of its condition.

## 5. Diaphragm and Center rod

### 5.1 Removal

#### ■ FAT, FST, BA□, BS□ types

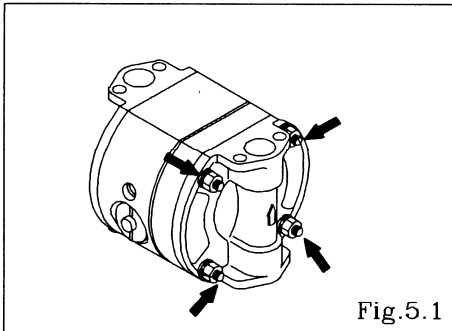

- Remove the ball or flat valve and valve seat (see “4.1 Removal FAT, FST, BA□, BS□ types”).
- Remove the 8 (12 on the NDP-15) retainer bolts from the out chamber, and remove the out chamber. [Fig.5.1]

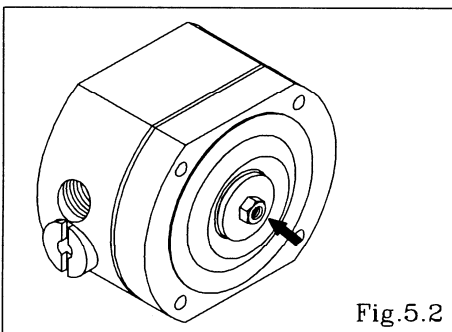

- Remove the nuts on both sides of the center rod. [Fig.5.2]
- After the nuts on one side have been removed, remove the center disk and diaphragm. Remove the diaphragm, center disk and center rod from the opposite side of the main body.

#### <NOTE>

- When the diaphragms are removed, the main body is separated 2 pieces. For easy work, leave the tie rods or bolts fastened temporarily before remove the diaphragms.

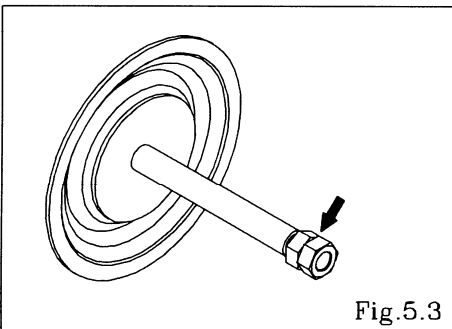

- Remove the nuts on the opposite side using the double nuts. [Fig.5.3]
- Remove the coned disk spring, center disk and diaphragm.

## ■FP□, BPS, FV□, FDT types

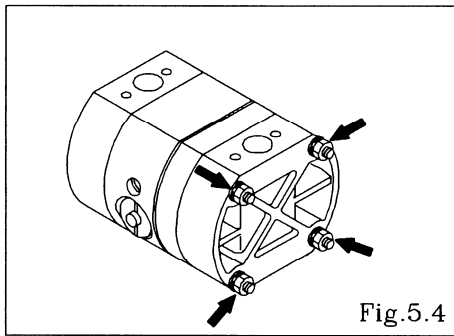

Fig.5.4

- Remove the flat valve and valve seat (see “4.1 Removal FP□, BPS, FV□, FDT types”).
- Remove the 8 (12 on the NDP-15) retainer nuts from the out chamber, and remove the out chamber. [Fig.5.4]

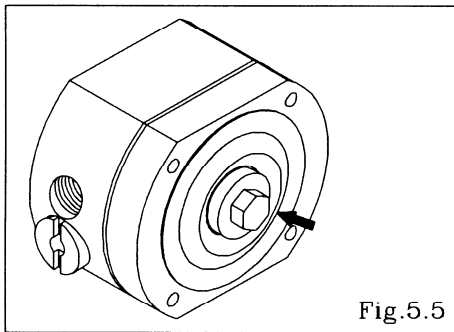

Fig.5.5

- Remove the center disk using the cap and disk remover. (special tool: Part No. 771132). (NDP-5FPT, FVT, FDT) [Fig.5.5]
- Remove the center disk from one side. (NDP-15) [Fig.5.5]
- After the center disk (outside) has been removed, remove the diaphragm and the center disk (inside).
- Remove the center disk and center rod from the opposite side of the main body.

### <NOTE>

- When the diaphragms are removed, the main body is separated 2 pieces. For easy work, leave bolts fastened temporarily before remove the diaphragms.

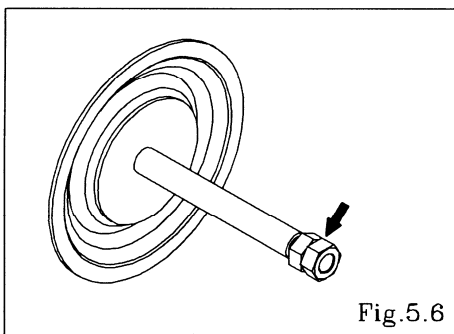

Fig.5.6

- Fix a double nut to one end of the center rod and take the diaphragm and center disk off the opposite end. [Fig.5.6]
- Be careful not to scratch or score the center rod.

## 5.2 Inspection

- Diaphragm

If the diaphragm is worn out or damaged, replace it.  
Never replace just one diaphragm.

### Frequency of inspecting the diaphragms (Transferring water at room temperature)

NDP-5	PTFE	30,000,000 cycle
NDP-15	CR, NBR, PTFE	10,000,000 cycle
	TPEE, TPO	15,000,000 cycle

\*The standard in our facility is ‘Air supply pressure 0.5 MPa with no discharge pressure.

\*It’s recommended to conduct an inspection, if 3 months have passed since you start using the pump, or if the number of cycles reaches the above.

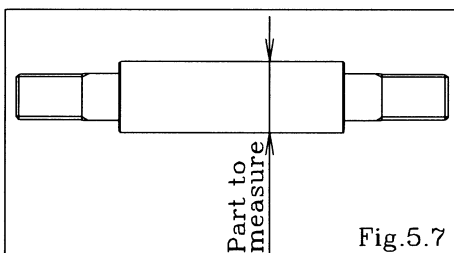

Fig.5.7

- Center rod [Fig.5.7]

Measure the diameter, and if it is outside the usable range, replace the rod.

### Usable range of center rod

NDP-5	ø 9.95 - ø 10.0 mm
NDP-15	ø 13.96 - ø 14.0 mm

## 5.3 Installation

### ■ B□H, B□S, FPH, F□S types

For installation, see [Exploded View] on the separate sheet and install in the reverse order of disassembly.

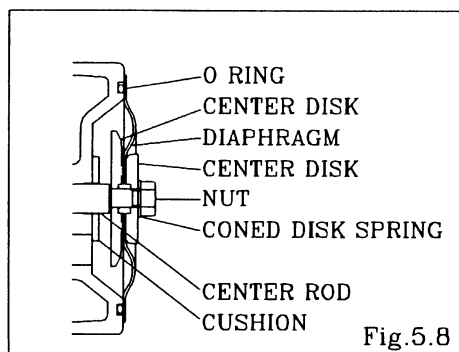

- Apply grease to the center rod, and insert it into the main body.
- Keep the convex side to the outside.
- Tighten the center disk using the open-end wrenches for the NDP-15FP□, BPS, FVS.  
(No coned disk springs and nuts are needed.)
- Tighten the out chamber temporarily at first.
- After installation of the out chambers on both sides, place the pump on a flat surface and stand the pump upright for further assembly.

Tightening torque for center rod and out chamber

	Center rod	Out chamber
NDP-15	14 N·m	12 N·m

<NOTE>

- Make sure there is no dust on the seal surface in order to prevent seal damaged.
- Tighten the bolts that balance should be equal from both side on diagonal line with even torque.

### ■ B□C, B□N, B□T, FPC, FPN, F□T types

For installation, see [Exploded View] on the separate sheet and install in the reverse order of disassembly.

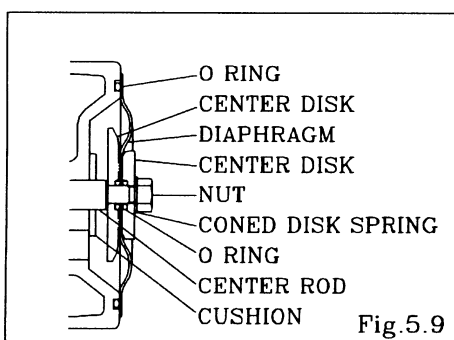

- Apply grease to the center rod, and insert it into the main body.
- Keep the marking "LIQUID" to liquid end for CR, NBR diaphragms.
- Keep the convex side to the outside for PTFE diaphragm.
- Put the O rings to both sides of the diaphragm. (cf. Fig.5.9).
- Tighten the cap and disk remover using the Accessory tool (special tool: Part No. 771132) for the NDP-5FPT, FVT, FDT types.
- Tighten the center disk using the open-end wrenches for the NDP-15FP□, F□T (No coned disk springs and nuts are needed.)
- Draw the center disk to one side, (cf. Fig.5.9) and install the out chamber. Tighten the bolts temporarily.
- Draw the center disk to the opposite side, then turn the diaphragm over (cf. Fig.5.9). And install the out chamber. Tighten the bolts temporarily.
- After installation of the out chambers on both sides, place the pump on a flat surface and stand the pump upright for further assembly.

Tightening torque for center rod and out chamber

	Center rod	Out chamber
NDP-5	7.5 N·m	6 N·m
NDP-15	14 N·m	12 N·m

< NOTE >

- Make sure there is no dust on the seal surface in order to prevent seal damaged.
- Replace the PTFE O ring by new one.
- Tighten the bolts that balance should be equal from both side on diagonal line with even torque.

## 6. Pilot valve Assembly, Guide and Bushing

### 6.1 Removal

#### ■ NDP-5

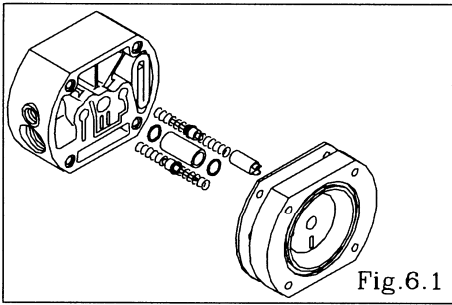

- Remove the cap using the cap and disk remover (see “5.1 Removal”).
- Remove the main body. [Fig.6.1]
- Draw out the pilot valve assembly. [Fig.6.1]
- Remove the packing and bushing. [Fig.6.1]

#### ■ NDP-15

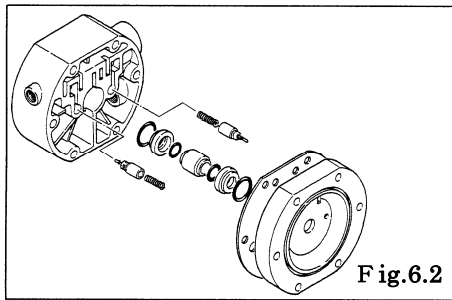

- Remove the diaphragm and center rod etc. (see “5.1 Removal”).
- Remove the body B. [Fig.6.2]
- Draw out the pilot valve assembly. [Fig.6.2]
- Remove the packing, bushing and guide. [Fig.6.2]

### 6.2 Inspection

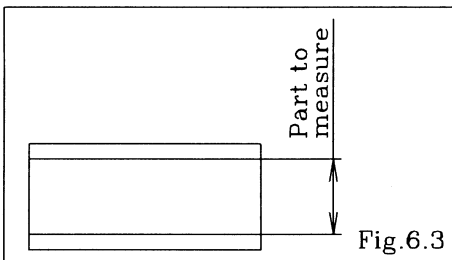

- Bushing (NDP-5) [Fig.6.3]  
Measure the inside diameter, and if it is outside the usable range, replace the bushing.

Usable range of bushing

Ø 10.1 - Ø 10.3 mm

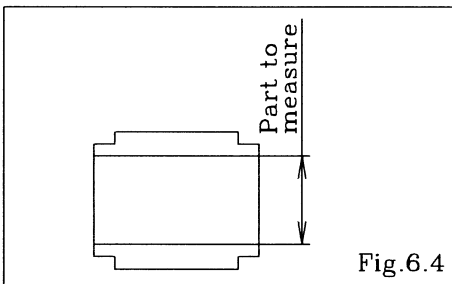

- Guide (NDP-15) [Fig.6.4]  
Measure the inside diameter, and if it is outside the usable range, replace the guide.

Usable range of guide

Ø 14.1 - Ø 14.2 mm

- O ring, Packing  
If the O ring is worn out or cracked, replace it.
- Pilot valve assembly  
If the pilot valve is worn out or cracked, replace it.

### 6.3 Installation

For installation, see [Exploded View] on the separate sheet and install in the reverse order of disassembly.

The correct direction of the V packing

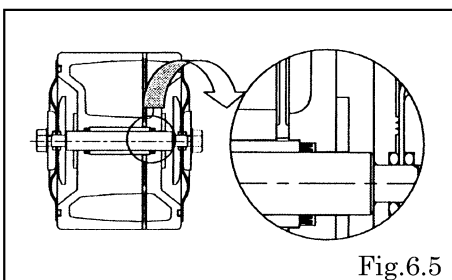

<NOTE>

- Make sure there is no dust on the seal surface and the seal is not damaged.
- Apply grease to packing.
- The open side of the V faces toward the diaphragm (air chamber).

## 7. C spool valve assembly and Sleeve assembly

### 7.1 Removal

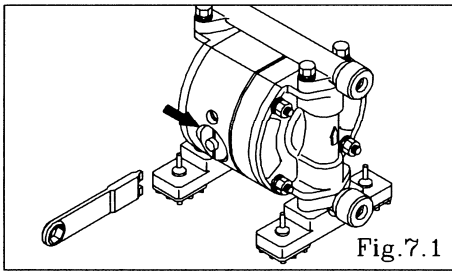

- Remove the cap using the cap and disk remover. (special tool: Part No. 771132). [Fig.7.1]

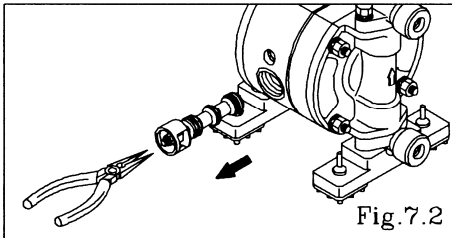

- Draw out the C spool valve assembly using the pleyer, and remove the seal ring from the C spool valve assembly. [Fig.7.2]

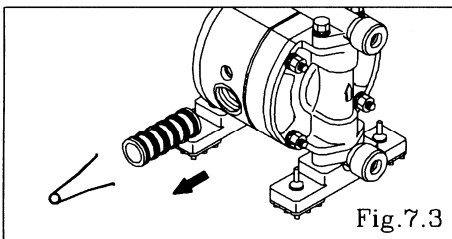

- Remove the sleeve using the sleeve remover (special tool: Part number 713148). [Fig.7.3]

### 7.2 Inspection

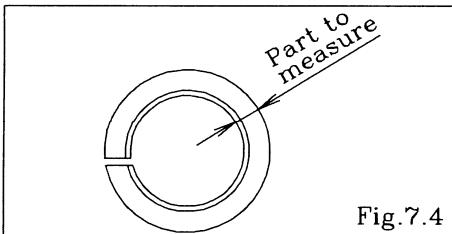

- C Spool valve Assembly Seal ring [Fig.7.4]

Measure the inside thick diameter, and if it is outside the usable range, replace the c spool valve assembly.

If the seal ring is worn out or cracked, replace c spool Valve assembly.

Usable range of seal ring

NDP-5	1.40 - 1.48 mm
NDP-15	1.82 - 1.90 mm

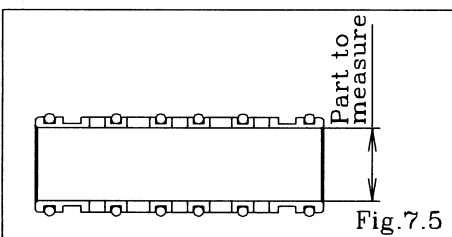

- Sleeve Assembly [Fig.7.5]

Measure the inside diameter, and if it is outside the usable range, replace the sleeve assembly.

Usable range of Sleeve

NDP-5	∅ 9.5 - ∅ 9.55 mm
NDP-15	∅ 15.8 - ∅ 15.85 mm

- O ring

If the O ring is worn out or cracked, replace it.

<NOTE>

- C Spool Valve Assembly and Sleeve Assembly must be replaced complete set. Unable to replace individual component.

### 7.3 Installation

For installation, see [Exploded View] on the separate sheet and install in the reverse order of disassembly.

<NOTE>

- Make sure there is no dust on the seal surface and it is not damaged.

### 8. Retightening of Tie rods

#### ■ Metal type

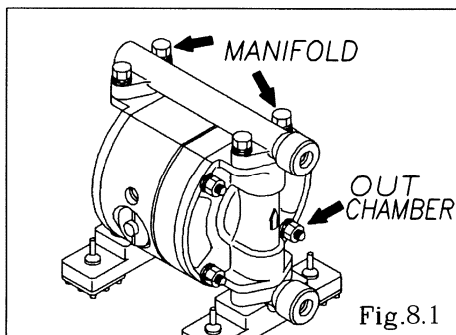

- The torque should be applied on the occasion of
  - (1) Right before the pump to use.
  - (2) There are any leaks of material on daily inspecting a pump.

		Retainer bolts from the out chamber	Retainer bolts from the manifold
NDP-5	FAT, FST	6 N•m	
NDP-15	BA□, BS□	12 N•m	

<NOTE>

- Tighten the bolts that balance should be equal from both side on diagonal line with even torque.
- Retighten the Out chamber and then the manifold in this order. [Fig.8.1]

#### ■ Plastic type

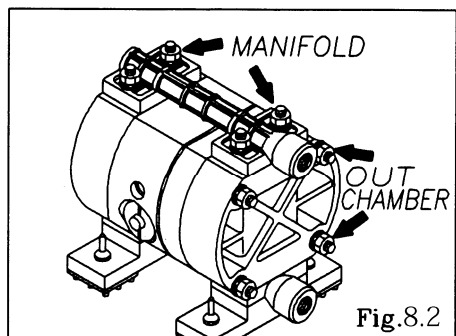

- The torque should be applied on the occasion of
  - (1) Right before the pump to use.
  - (2) There are any leaks of material on daily inspecting a pump.

		Retainer bolts from the out chamber	Retainer bolts from the manifold
NDP-5	FPT, FVT, FDT	6 N•m	
NDP-15	FP□, BPS, FV□	12 N•m	

<NOTE>

- Tighten the bolts that balance should be equal from both side on diagonal line with even torque.
- Retighten the Out chamber and then the manifold in this order. [Fig.8.2]

## **YAMADA EUROPE B.V.**

Aquamarijnstraat 50,7554 NS Hengelo (O),The Netherlands

PHONE : +31-(0)74-242-2032

FAX : +31-(0)74-242-1055

E-mail : sales@yamada.nl

Web : www.yamada-europe.com

Manufactured by

## **YAMADA CORPORATION**

**INTERNATIONAL DEPARTMENT**

1-1-3, Minami-Magome,Ota ku, Tokyo, 143-8504, Japan

PHONE : +81-(0)3-3777-0241

FAX : +81-(0)3-3777-0584

E-mail : intl@yamadacorp.co.jp

Web : www.yamadacorp.co.jp

202411.2829 NDP008M