

EXPLODED VIEW & PARTS LISTING

Air Operated Double Diaphragm pump

Model : NDP-15BS.

Yamada Europe B.V.



Material: Stainless Steel 316 (SCS14)

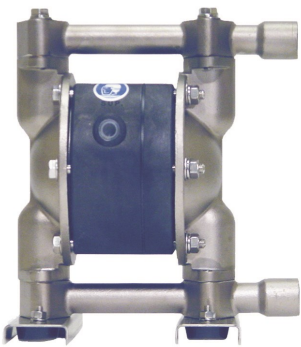

To Purchase:

More information:

☎ 0031 (0)74 242 2032

▶ YouTube: [@yamadapump](https://www.youtube.com/@yamadapump)

✉ sales@yamada.nl

🌐 yamada-europe.com

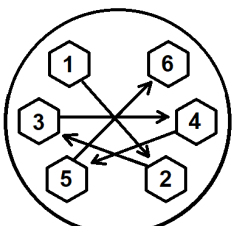
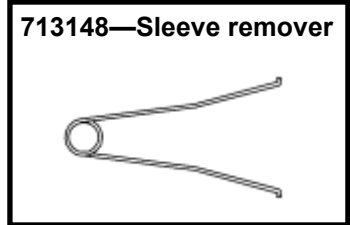
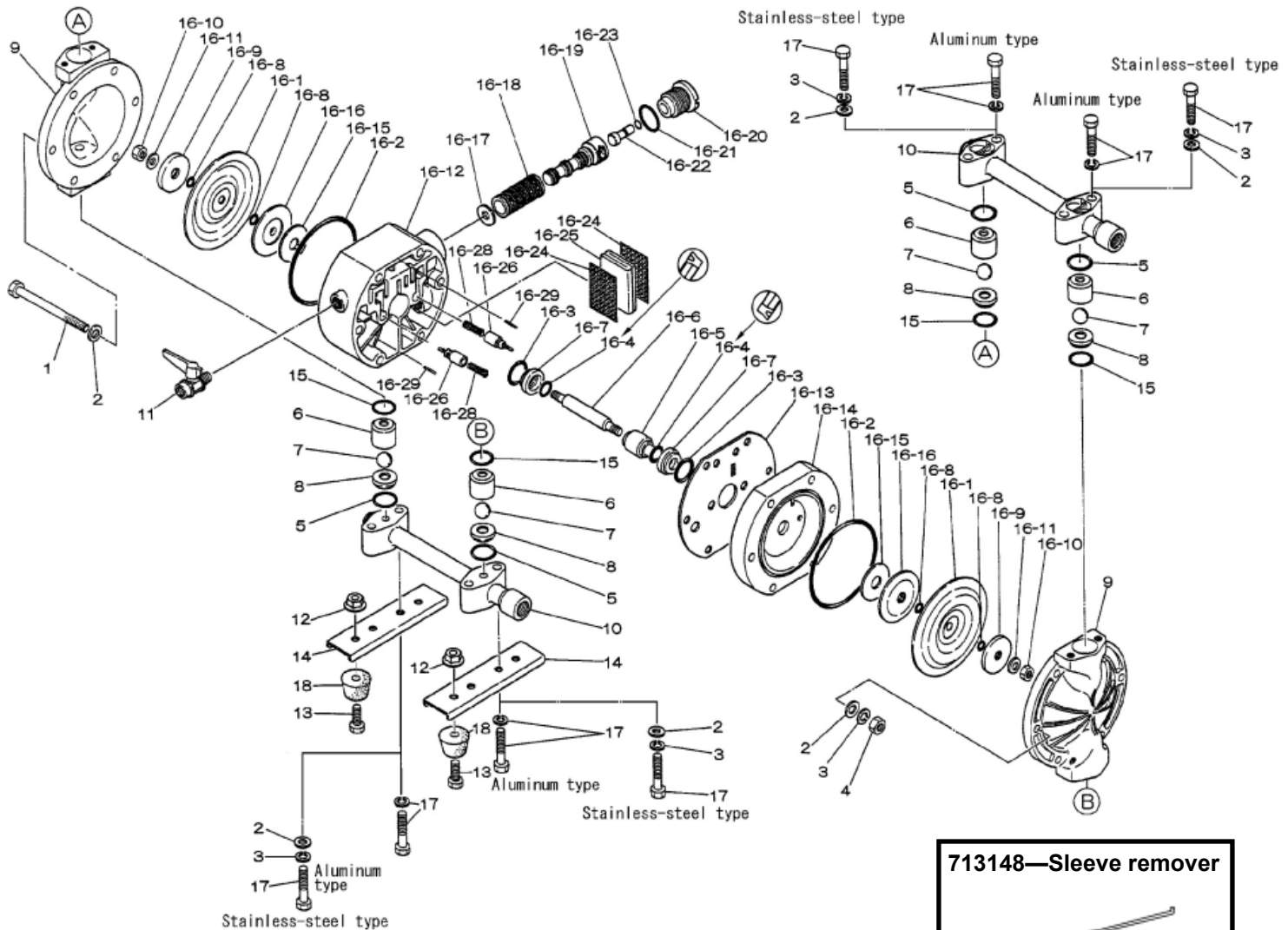

Tighting torque for:

Center rod:	14Nm
Out chambers:	12Nm
Manifolds:	12Nm

Special tools (sold seperately)

713148 Sleeve remover

Miscellaneous:

Assembly oil: use turbine oil none additional class 1
 Equiv. to ISO VGA32 grade
 Use Urea grease grade NLGI No. 2

EXPLODED VIEW & PARTS LISTING

Air Operated Double Diaphragm pump

Model : NDP-15BS.

Yamada Europe B.V.



Material: Stainless Steel 316 (SCS14)



DIAPHRAGM

Design #

REF. No.	DESCRIPTION	Q'TY.	Material					
			CR	NBR	HYTREL	SANTOPRENE	PTFE	PTFE-EPDM
			BSC	BSN	BSH	BSS	BST	BSTU
			851958	851959	851960	852681	851957	YE Original
			Part No.	Part No.	Part No.	Part No.	Part No.	Part No.
1	BOLT	6	683224	683224	683224	683224	683224	683224
2	PLAIN WASHER	20	631329	631329	631329	631329	631329	631329
3	SPRING WASHER	14	681300	681300	681300	681300	681300	681300
4	NUT	6	687229	687229	687229	687229	687229	687229
5	O RING	4	640025	640025	640025	684114	643025	643025
6	BALL GUIDE	4	711502	711502	711502	711502	711502	711502
7	BALL	4	771526	771525	773125	773169	771524	771524
8	VALVE SEAT	4	711382	711382	711382	711382	711382	711382
9	OUT CHAMBER	2	711380	711380	711380	711380	711380	711380
10	MANIFOLD	2	711501	711501	711501	711501	711501	711501
11	VALVE	1	686825	686825	686825	686825	686825	686825
12	FLANGED NUT	4	682817	682817	682817	682817	682817	682817
13	BOLT	4	611101	611101	611101	611101	611101	611101
14	BASE	2	717185	717185	717185	717185	717185	717185
15	O RING	4	640130	640130	640130	684113	643130	643130
16	BODY ASSY	1	802997	802998	802999	803503	802996	802996-TU
16-1	DIAPHRAGM	2	770971	770973	771372	771972	770933	833027
16-2	O RING	2	640144	640144	640144	640144	640144	640144
16-3	O RING	2	640020	640020	640020	640020	640020	640020
16-4	PACKING	2	684284	684284	684284	684284	684284	684284
16-5	GUIDE	1	771337	771337	771337	771337	771337	771337
16-6	CENTER ROD	1	710578	710578	710578	710578	710578	716573
16-7	BUSHING	2	771336	771336	771336	771336	771336	771336
16-8	O RING	4	640005	640005	-	-	643005	-
16-9	CENTER DISK	2	708506	708506	708506	708506	708506	-
16-10	NUT	2	681849	681849	681849	681849	681849	-
16-11	CONED DISC SPRING	2	684916	684916	684916	684916	684916	-
16-12	BODY A	1	780028	780028	780028	780028	780028	780028
16-13	GASKET	1	771347	771347	771347	771347	771347	771347
16-14	BODY B	1	780030	780030	780030	780030	780030	780030
16-15	CUSHION	2	771342	771342	771342	771342	771342	771342
16-16	CENTER DISK	2	771344	771344	771344	771344	771344	020109
16-17	CUSHION	1	771483	771483	771483	771483	771483	771483
O-rings sleeve	16-18	SLEEVE ASSY	1	804249	804249	804249	804249	804249
16-19	C SPOOL ASSY	1	802835	802835	802835	802835	802835	802835
16-20	CAP	1	771695	771695	771695	771695	771695	771695
16-21	O RING	1	640022	640022	640022	640022	640022	640022
16-22	RESET BUTTON	1	771350	771350	771350	771350	771350	771350
16-23	O RING	1	640002	640002	640002	640002	640002	640002
16-24	MESH	2	771589	771589	771589	771589	771589	771589
16-25	MUFFLER FELT	1	771465	771465	771465	771465	771465	771465
16-26	PILOT VALVE ASSY	2	832141	832141	832141	832141	832141	832141
16-28	SPRING	2	710577	710577	710577	710577	710577	710577
16-29	SPRING PIN	2	632752	632752	632752	632752	632752	632752
17	BOLT	8	621155	621155	621155	621155	621155	621155
18	RUBBER FOOT	4	771123	771123	771123	771123	771123	771123
KIT	DIAPHRAGM		K15D-MC	K15D-MN	K15D-MH	K15D-MS	K15D-MT	K15D-MTU
KIT	VALVE		K15V-SC	K15V-SN	K15V-SH	K15V-SS	K15V-ST	K15V-ST
KIT	WET END REPAIR		K15-MC	K15-MN	K15-MH	K15-MS	K15-MT	K15-MTU
KIT	AIR MOTOR		K10/15-AM					
KIT	AIR MOTOR SEAL		K10/15-AMS					

EXPLODED VIEW & PARTS LISTING

Air Operated Double Diaphragm pump

Model : NDP-15BS.

Yamada Europe B.V.



Material: Stainless Steel 316 (SCS14)



MODEL : NDP-15BS.

Diaphragm options	CR, NBR, TPEE, TPO	PTFE	TU
Max performance	50 L/min	45 L/min	42 L/min
Manifold connection	Rc 1/2"		
Net Weight	6,2 kg		

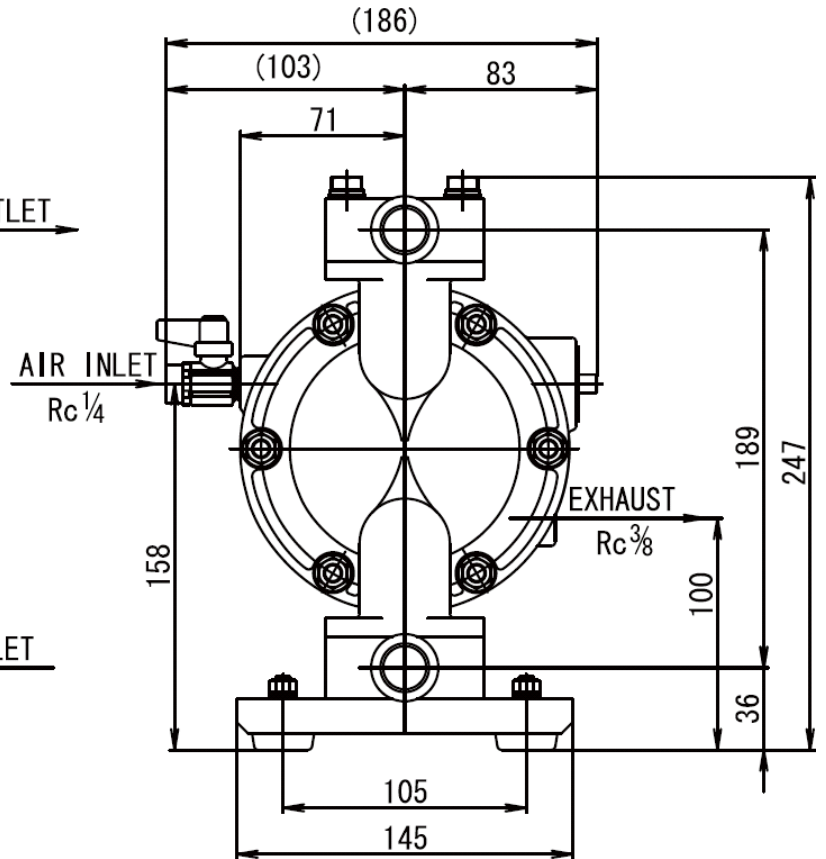
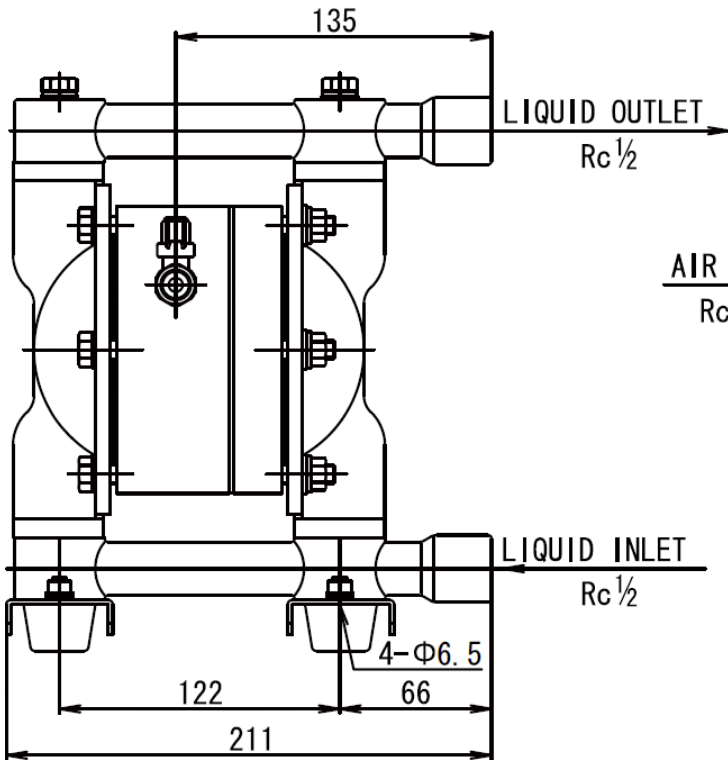

0,1MPa = 1Bar

