

EXPLODED VIEW & PARTS LISTING

Air Operated Double Diaphragm pump

Model : NDP-15BS.

Yamada Europe B.V.



Material: Stainless Steel 316 (SCS14)

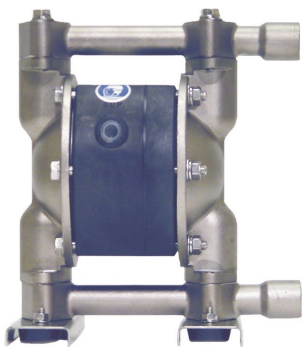

To Purchase:

More information:

☎ 0031 (0)74 242 2032

▶ YouTube: [@yamadapump](https://www.youtube.com/@yamadapump)

✉ sales@yamada.nl

🌐 yamada-europe.com

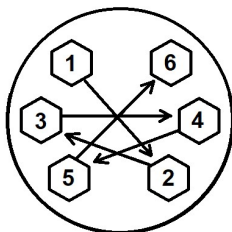
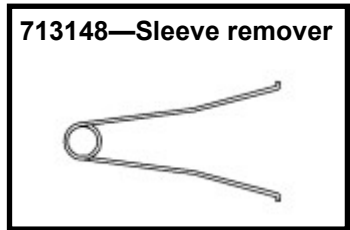
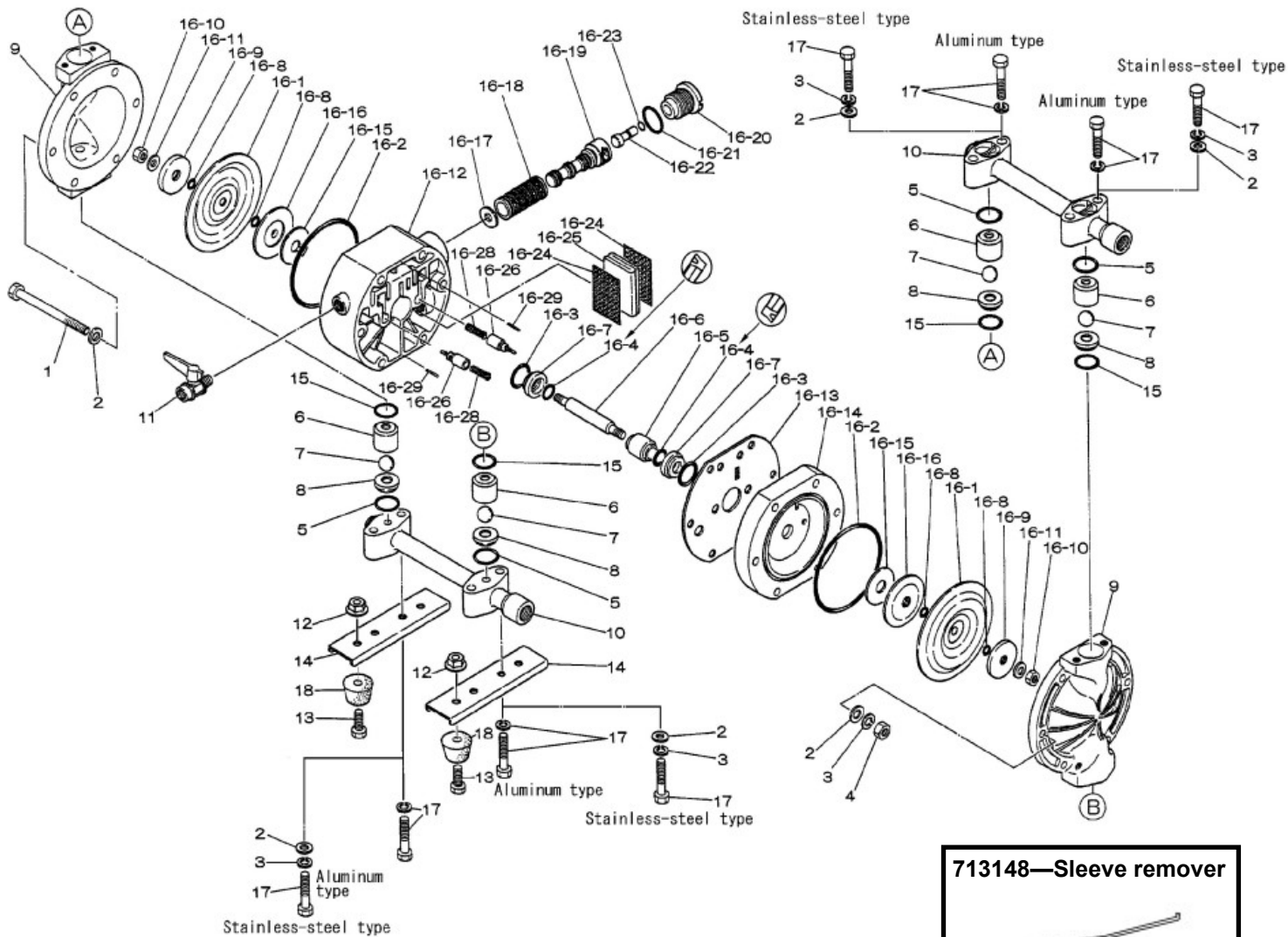

Tighting torque for:

Center rod:	14Nm
Out chambers:	12Nm
Manifolds:	12Nm

Special tools (sold seperately)

- 713148 Sleeve remover
- 771132 Cap and disk remover

Miscellaneous:

- Assembly oil: use turbine oil none additional class 1
- Equiv. to ISO VGA32 grade
- Use Urea grease grade NLGI No. 2

EXPLODED VIEW & PARTS LISTING

Air Operated Double Diaphragm pump

Model : NDP-15BS.

Yamada Europe B.V.



Material: Stainless Steel 316 (SCS14)



DIAPHRAGM

Design #

REF. No.	DESCRIPTION	Q'TY.	CR	NBR	HYTREL	SANTOPRENE	PTFE	PTFE-EPDM	VITON
			BSC	BSN	BSH	BSS	BST	BSTU	BSV
			851958	851959	851960	852681	851957	YE Original	YE Original
Part No.	Part No.	Part No.	Part No.	Part No.	Part No.	Part No.	Part No.	Part No.	
1	BOLT	6	683224	683224	683224	683224	683224	683224	683224
2	PLAIN WASHER	20	631329	631329	631329	631329	631329	631329	631329
3	SPRING WASHER	14	681300	681300	681300	681300	681300	681300	681300
4	NUT	6	687229	687229	687229	687229	687229	687229	687229
5	O RING	4	640025	640025	640025	684114	643025	643025	643025
6	BALL GUIDE	4	711502	711502	711502	711502	711502	711502	711502
7	BALL	4	771526	771525	773125	773169	771524	771524	771524-V
8	VALVE SEAT	4	711382	711382	711382	711382	711382	711382	711382
9	OUT CHAMBER	2	711380	711380	711380	711380	711380	711380	711380
10	MANIFOLD	2	711501	711501	711501	711501	711501	711501	711501
11	VALVE	1	686825	686825	686825	686825	686825	686825	686825
12	FLANGED NUT	4	682817	682817	682817	682817	682817	682817	682817
13	BOLT	4	611101	611101	611101	611101	611101	611101	621102
14	BASE	2	717185	717185	717185	717185	717185	717185	717185
15	O RING	4	640130	640130	640130	684113	643130	643130	643130
16	BODY ASSY	1	802997	802998	802999	803503	802996	802996-TU	802996-V
16-1	DIAPHRAGM	2	770971	770973	771372	771972	770933	833027	770971-V
16-2	O RING	2	640144	640144	640144	640144	640144	640144	640144
16-3	O RING	2	640020	640020	640020	640020	640020	640020	640020
16-4	PACKING	2	684284	684284	684284	684284	684284	684284	683058
16-5	GUIDE	1	771337	771337	771337	771337	771337	771337	771337
16-6	CENTER ROD	1	710578	710578	710578	710578	710578	716573	710578
16-7	BUSHING	2	771336	771336	771336	771336	771336	771336	771336
16-8	O RING	4	640005	640005	—	—	643005	—	642005
16-9	CENTER DISK	2	708506	708506	708506	708506	708506	—	708770
16-10	NUT	2	681849	681849	681849	681849	681849	—	—
16-11	CONED DISC SPRING	2	684916	684916	684916	684916	684916	—	—
16-12	BODY A	1	780028	780028	780028	780028	780028	780028	780028
16-13	GASKET	1	771347	771347	771347	771347	771347	771347	771347
16-14	BODY B	1	780030	780030	780030	780030	780030	780030	780030
16-15	CUSHION	2	771342	771342	771342	771342	771342	771342	771342
16-16	CENTER DISK	2	771344	771344	771344	771344	771344	020109	771344
16-17	CUSHION	1	771483	771483	771483	771483	771483	771483	771483
16-18	SLEEVE ASSY	1	804249	804249	804249	804249	804249	804249	804249
16-19	C SPOOL ASSY	1	802835	802835	802835	802835	802835	802835	802835
16-20	CAP	1	771695	771695	771695	771695	771695	771695	771695
16-21	O RING	1	640022	640022	640022	640022	640022	640022	640022
16-22	RESET BUTTON	1	771350	771350	771350	771350	771350	771350	771350
16-23	O RING	1	640002	640002	640002	640002	640002	640002	640002
16-24	MESH	2	771589	771589	771589	771589	771589	771589	771589
16-25	MUFFLER FELT	1	771465	771465	771465	771465	771465	771465	771465
16-26	PILOT VALVE ASSY	2	832141	832141	832141	832141	832141	832141	832141
16-28	SPRING	2	710577	710577	710577	710577	710577	710577	710577
16-29	SPRING PIN	2	632752	632752	632752	632752	632752	632752	632752
17	BOLT	8	621155	621155	621155	621155	621155	621155	621155
18	RUBBER FOOT	4	771123	771123	771123	771123	771123	771123	771123
KIT	DIAPHRAGM		K15D-MC	K15D-MN	K15D-MH	K15D-MS	K15D-MT	K15D-MTU	K15D-MV
KIT	VALVE		K15V-SC	K15V-SN	K15V-SH	K15V-SS	K15V-ST	K15V-ST	K15V-SV
KIT	WET END REPAIR		K15-MC	K15-MN	K15-MH	K15-MS	K15-MT	K15-MTU	K15-MV
KIT	AIR MOTOR		K10/15-AM						
KIT	AIR MOTOR SEAL		K10/15-AMS						

EXPLODED VIEW & PARTS LISTING

Air Operated Double Diaphragm pump

Model : NDP-15BS.

Yamada Europe B.V.



Material: Stainless Steel 316 (SCS14)



MODEL : NDP-15BS.

Diaphragm options	CR, NBR, TPEE, TPO	PTFE	TU
Max performance	50 L/min	45 L/min	42 L/min
Manifold connection	Rc 1/2"		
Transport box sizes	W27cm x D25cm x H37cm		
Brutto Weight	6,7 kg		
Net Weight	6,2 kg		

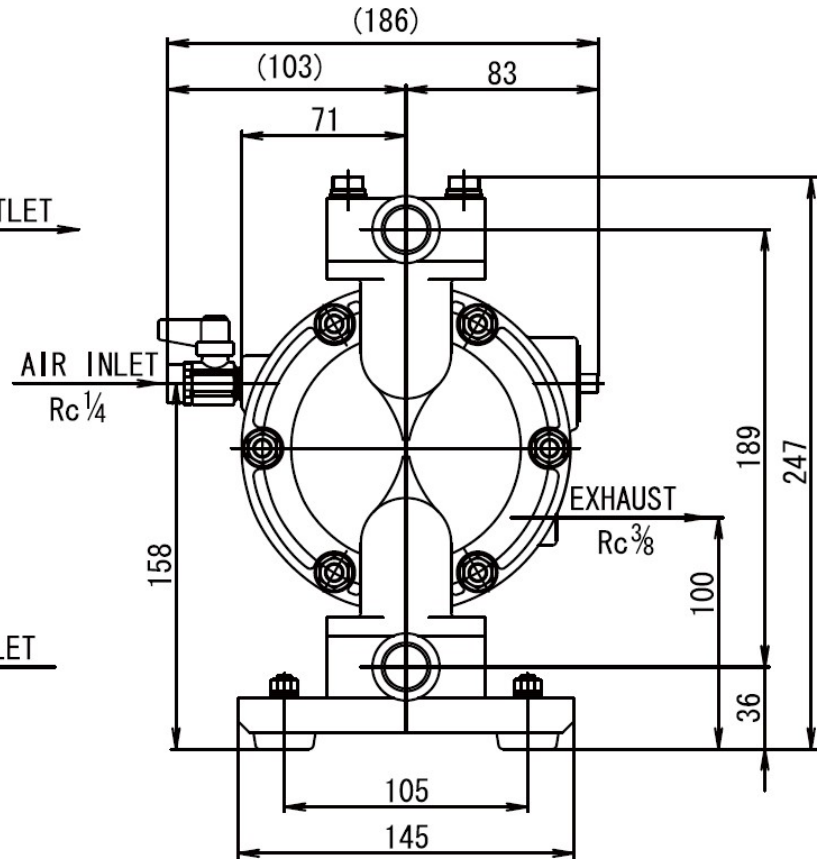
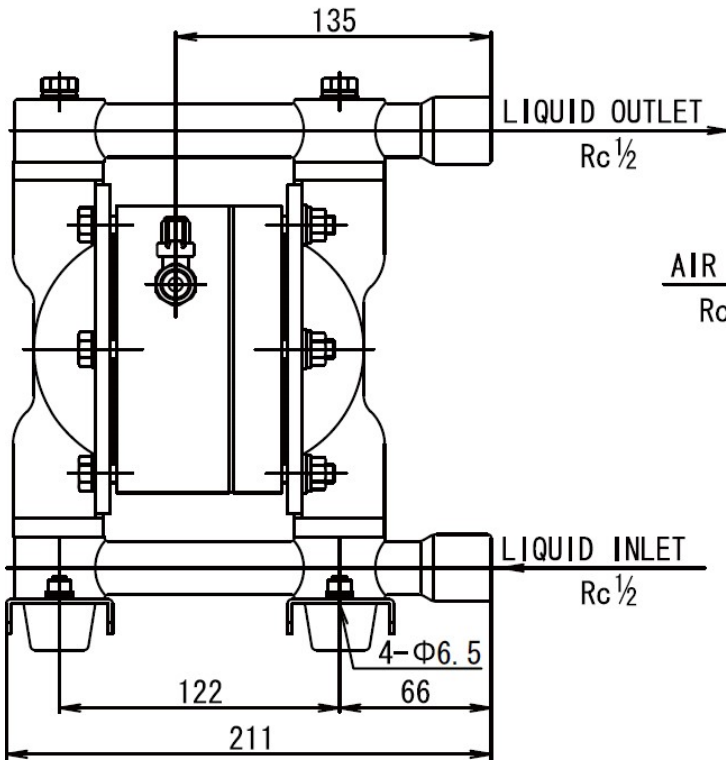

0,1MPa = 1Bar

