

EXPLODED VIEW & PARTS LISTING

Model : NDP-50BA.-RC

Yamada Europe B.V.



Air Operated Double Diaphragm pump

Material: Aluminium (ADC12)



To Purchase:

More information:

☎ 0031 (0)74 242 2032

▶ YouTube: [@yamadapump](#)

✉ sales@yamada.nl

🌐 yamada-europe.com

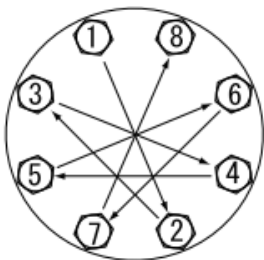
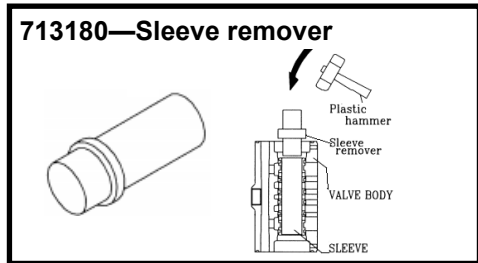
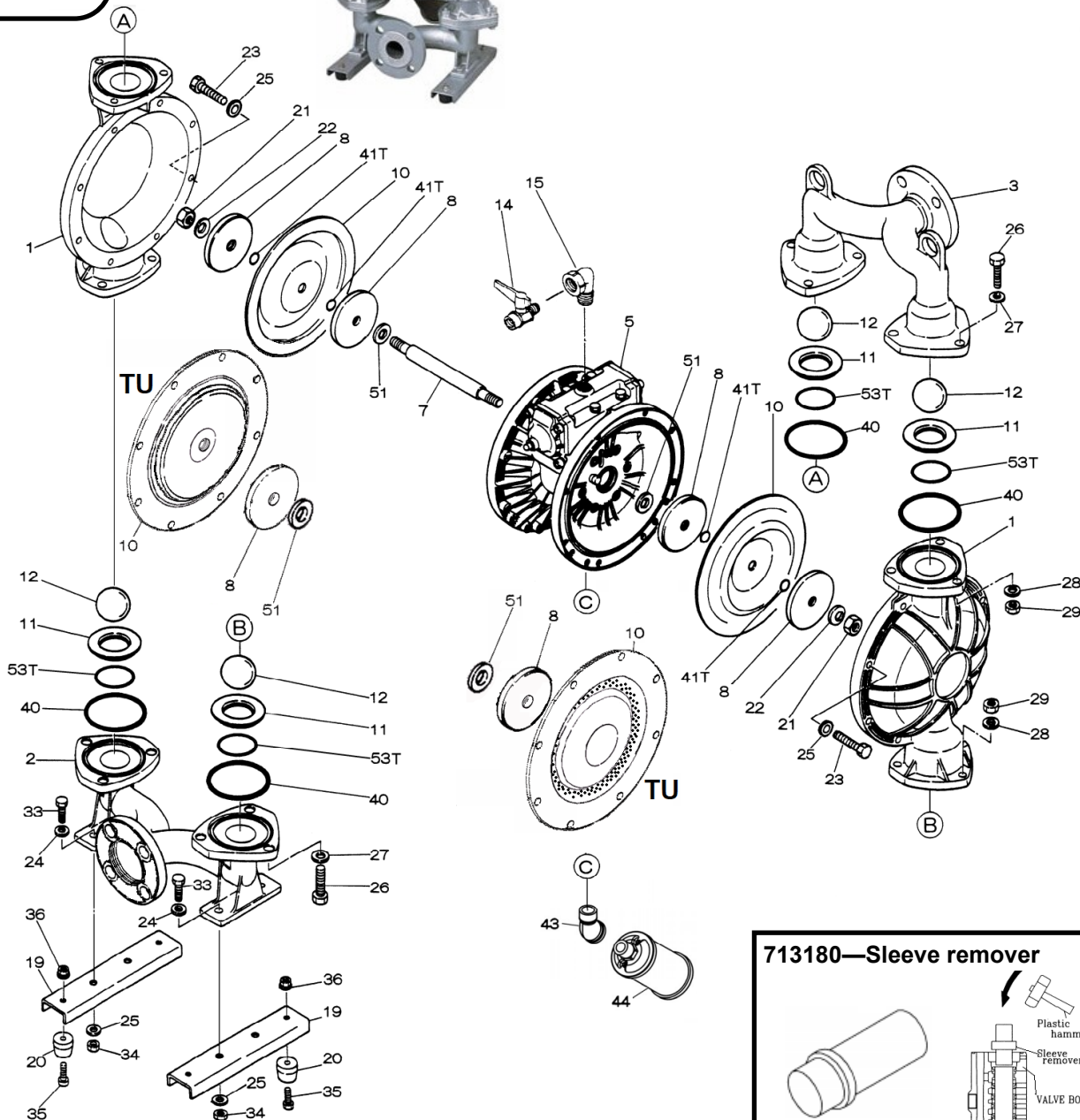

Tighting torque for:

Center rod: 60 Nm
 Center rod TU: **Hand tight**
 Out chamber: 40 Nm
 Manifold: 25 Nm

Special tools (sold seperately)

713180 Sleeve remover

Miscellaneous:

Assembly oil: use turbine oil none additional class 1
 Equiv. to ISO VGA32 grade
 Use Urea grease grade NLGI No. 2



Body Assembly

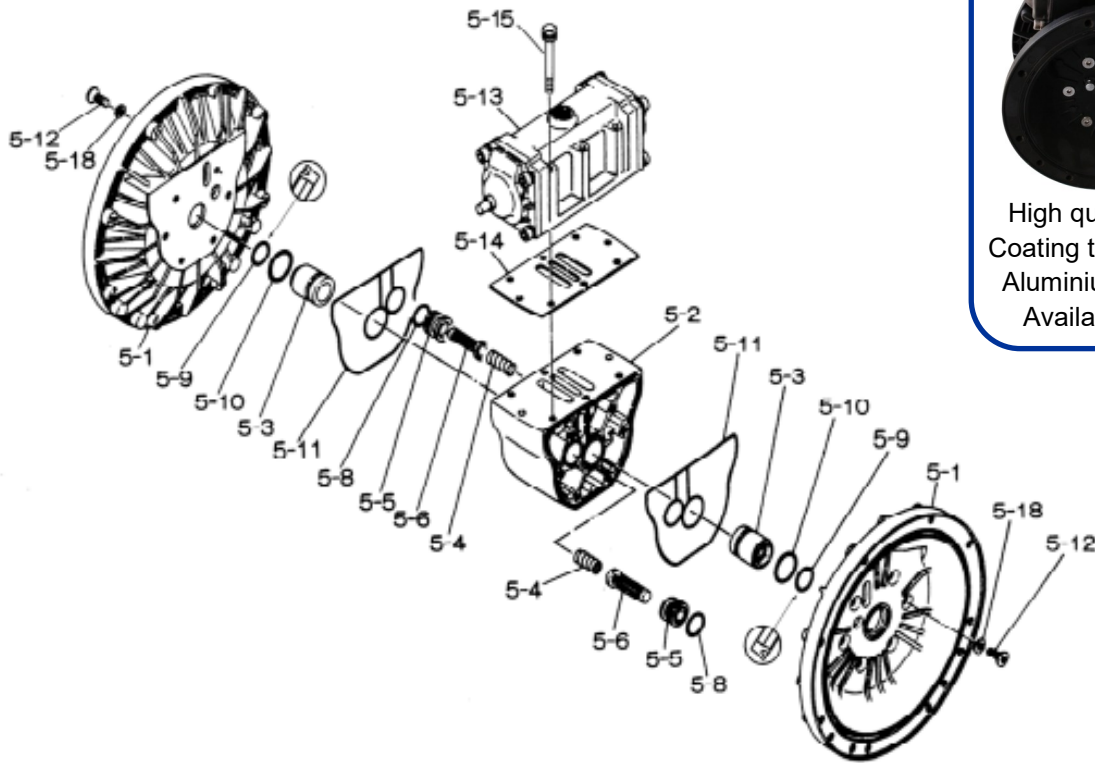

High quality PTFE Coating to protect the Aluminium motor is Available. (-XS)

Valve Body Assembly

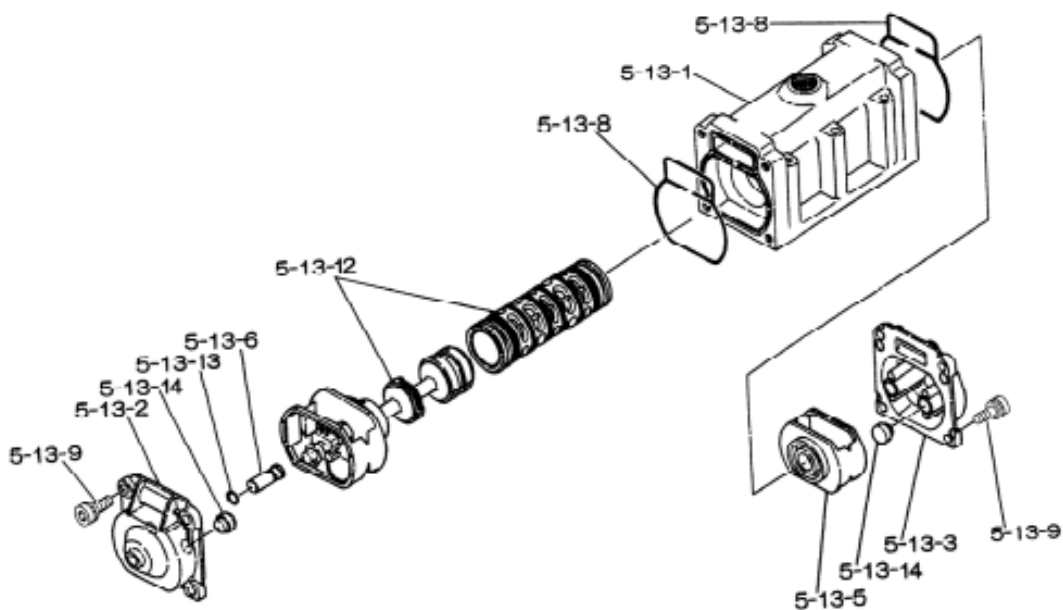

EXPLODED VIEW & PARTS LISTING

Model : NDP-50BA.-RC

Yamada Europe B.V.



Air Operated Double Diaphragm pump

Material: Aluminium (ADC12)

DIAPHRAGM

Design #

CR	NBR	EPDM	HYTREL	SANTOPRENE	FPM	PTFE	PTFE-EPDM
BAC	BAN	BAE	BAH	BAS	BAV	BAT	BATU
854773	854774	854775	854778	854779	854776	854777	YE Original



REF. No.	DESCRIPTION	Q'TY.	Part No.	Part No.	Part No.	Part No.	Part No.	Part No.	Part No.	Part No.	Part No.
1	OUT CHAMBER	2	580961	580961	580961	580961	580961	580961	580961	580961	580961
2	IN MANIFOLD (FLANGE RC)	1	716682	716682	716682	716682	716682	716682	716682	716682	716682
3	OUT MANIFOLD (FLANGE RC)	1	716683	716683	716683	716683	716683	716683	716683	716683	716683
5	BODY ASSY	1	803122	803122	803122	803122	803122	803122	803122	803122	803122
5- 1	AIR CHAMBER	2	711934	711934	711934	711934	711934	711934	711934	711934	711934
5- 2	BODY	1	711947	711947	711947	711947	711947	711947	711947	711947	711947
*5- 3	THROAT BEARING	2	772689	772689	772689	772689	772689	772689	772689	772689	772689
5- 4	SPRING	2	711937	711937	711937	711937	711937	711937	711937	711937	711937
5- 5	VALVE SEAT	2	771740	771740	771740	771740	771740	771740	771740	771740	771740
5- 6	PILOT VALVE ASSY	2	832162	832162	832162	832162	832162	832162	832162	832162	832162
5- 8	O RING	2	640020	640020	640020	640020	640020	640020	640020	640020	640020
5- 9	PACKING	2	685444	685444	685444	685444	685444	685444	685444	685444	685444
5-10	O RING	2	640029	640029	640029	640029	640029	640029	640029	640029	640029
5-11	GASKET	2	771742	771742	771742	771742	771742	771742	771742	771742	771742
5-12	BOLT	12	683812	683812	683812	683812	683812	683812	683812	683812	683812
5-13	VALVE BODY ASSY	1	803120	803120	803120	803120	803120	803120	803120	803120	803120
5-13- 1	VALVE BODY	1	711946	711946	711946	711946	711946	711946	711946	711946	711946
5-13- 2	CAP A	1	580999	580999	580999	580999	580999	580999	580999	580999	580999
5-13- 3	CAP B	1	581000	581000	581000	581000	581000	581000	581000	581000	581000
5-13- 5	SPRING RETAINER	1	771735	771735	771735	771735	771735	771735	771735	771735	771735
5-13- 6	RESET BUTTON	1	712976	712976	712976	712976	712976	712976	712976	712976	712976
5-13- 8	GASKET	2	771738	771738	771738	771738	771738	771738	771738	771738	771738
5-13- 9	BOLT	8	685036	685036	685036	685036	685036	685036	685036	685036	685036
5-13-12	C SPOOL ASSY (C-spool + sleeve)	1	805084	805084	805084	805084	805084	805084	805084	805084	805084
5-13-13	O RING	1	640005	640005	640005	640005	640005	640005	640005	640005	640005
5-13-14	CUSHION	4	684128	684128	684128	684128	684128	684128	684128	684128	684128
5-14	GASKET	1	771712	771712	771712	771712	771712	771712	771712	771712	771712
5-15	BOLT & WASHER	6	684240	684240	684240	684240	684240	684240	684240	684240	684240
5-18	PLAIN WASHER	12	684987	684987	684987	684987	684987	684987	684987	684987	684987
7	CENTER ROD	1	711900	711900	711900	711900	711900	711900	711900	711939	717130
8	CENTER DISK DRY ALU	2	711904	711904	711904	711904	711904	711904	711904	707822	717133
8	CENTER DISK WET ALU	2	711904	711904	711904	711904	711904	711904	711904	707822	-
10	DIAPHRAGM	2	771855	771702	771856	771703	771976	771800	770815	833220	-
11	VALVE SEAT RUBBER	4	771957	771995	771949	771794	772004	771987	-	-	-
11	VALVE SEAT ALU	4	-	-	-	-	-	-	712383	712383	-
12	BALL	4	770627	770630	770633	773143	773173	770636	770693	770693	-
14	VALVE	1	686973	686973	686973	686973	686973	686973	686973	686973	686973
15	ELBOW	1	634034	634034	634034	634034	634034	634034	634034	634034	634034
19	BASE	2	711928	711928	711928	711928	711928	711928	711928	711928	711928
20	RUBBER FOOT	4	771402	771402	771402	771402	771402	771402	771402	771402	771402
21	NUT	2	683408	683408	683408	706128	683408	683408	706128	-	-
22	CONED DISC SPRING	2	682740	682740	682740	682740	682740	682740	682740	-	-
23	BOLT	16	686162	686162	686162	686162	686162	686162	686162	686162	686162
24	PLAIN WASHER	4	631014	631014	631014	631014	631014	631014	631014	631014	631014
25	WAVE WASHER	20	631917	631917	631917	631917	631917	631917	631917	631917	631917
26	BOLT	12	611203	611203	611203	611203	611203	611203	611203	611203	611203
27	PLAIN WASHER	12	631015	631015	631015	631015	631015	631015	631015	631015	631015
28	WAVE WASHER	12	631918	631918	631918	631918	631918	631918	631918	631918	631918
29	NUT	12	627014	627014	627014	627014	627014	627014	627014	627014	627014
33	BOLT	4	611175	611175	611175	611175	611175	611175	611175	611175	611175
34	NUT	4	627013	627013	627013	627013	627013	627013	627013	627013	627013
35	BOLT	4	611149	611149	611149	611149	611149	611149	611149	611149	611149
36	FLANGED NUT	4	682276	682276	682276	682276	682276	682276	682276	682276	682276
40	O RING	4	640069	640069	684122	640069	684122	642069	643069	643069	-
41T	O RING	4	-	-	-	-	-	-	643015	-	-
43	ELBOW	1	634050	634050	634050	634050	634050	634050	634050	634050	634050
44	MUFFLER	1	687235	687235	687235	687235	687235	687235	687235	687235	687235
51	CUSHION	2	770582	770582	770582	770582	770582	770582	-	773435	-
53T	O RING	4	-	-	-	-	-	-	643139	643139	-
KIT	DIAPHRAGM		K50D-MC	K50D-MN	K50D-ME	K50D-MH	K50D-MS	K50D-MV	K50D-MT	K50D-TU	-
KIT	VALVE		K50V-MC	K50V-MN	K50V-ME	K50V-MH	K50V-MS	K50V-MV	K50V-AT	K50V-AT	-
KIT	WET END REPAIR		K50-MC	K50-MN	K50-ME	K50-MH	K50-MS	K50-MV	K50-MT	K50-TU	-
KIT	AIR MOTOR										
KIT	AIR MOTOR SEAL										

* Throat bearing position 5-3, 772689 is only available as an assembly. Positions 5-3, 5-9 and 5-10. Article code 020689

EXPLODED VIEW & PARTS LISTING

Air Operated Double Diaphragm pump



MODEL : NDP-50BA-RC

Model : NDP-50BA-RC

yamada Europe B.V.



Material: Aluminium (ADC12)

Diaphragm options	CR, EPDM, NBR, FPM, TPEE, TPO, PTFE, TU
Max performance	630 L/min (PTFE 600 L/min)
	Equivalent to DIN; Flange DN50 PN10 + Inner Rc 2"
Manifold connection	ANSI Flange 150 2 + Inner Rc 2"
Net Weight	34,5 kg (PTFE 32,5 kg / TU 33,5 kg)

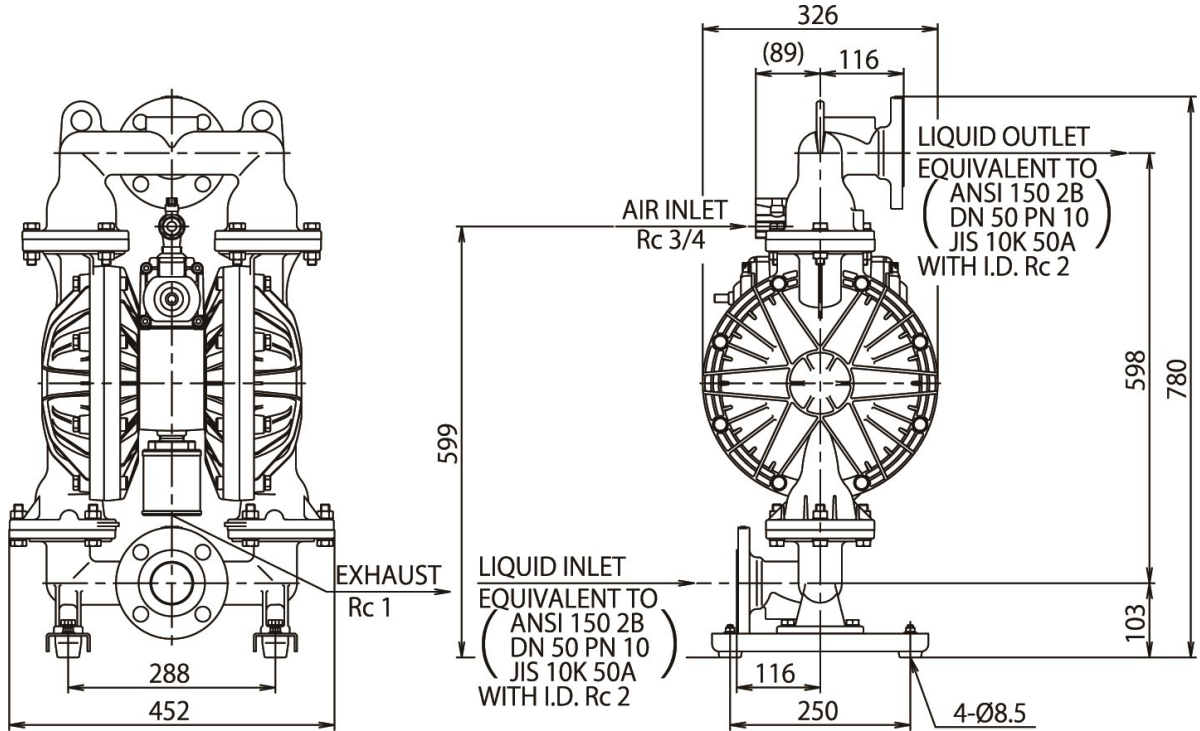

NDP-50BA □, BS □, BF □

0,1MPa = 1Bar

NDP-50BAT, BST, BFT

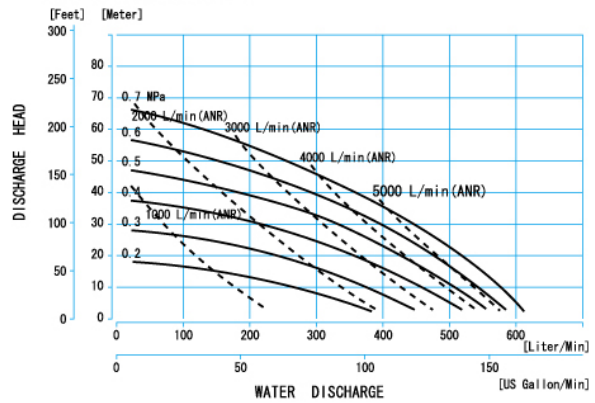
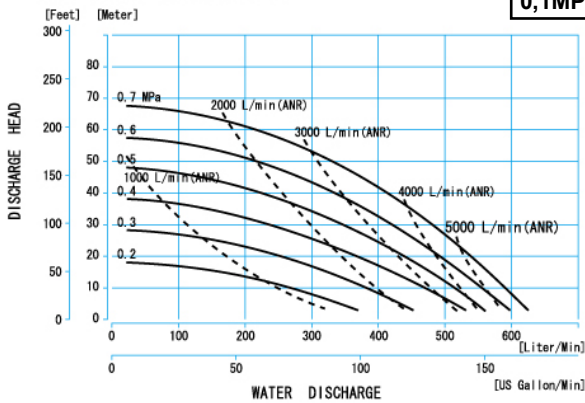

NDP-50BATU-RC, BFTU, BSTU

