

EXPLODED VIEW & PARTS LISTING

Air Operated Double Diaphragm pump

Model : NDP-5FDT

Yamada Europe B.V.



Material : POM (Conductive Polyacetal)



To Purchase:

More information:

☎ 0031 (0)74 242 2032

▶ YouTube: [@yamadapump](https://www.youtube.com/@yamadapump)

✉ sales@yamada.nl

🌐 yamada-europe.com

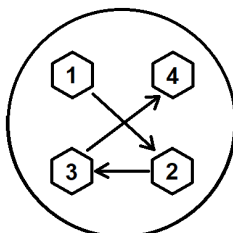
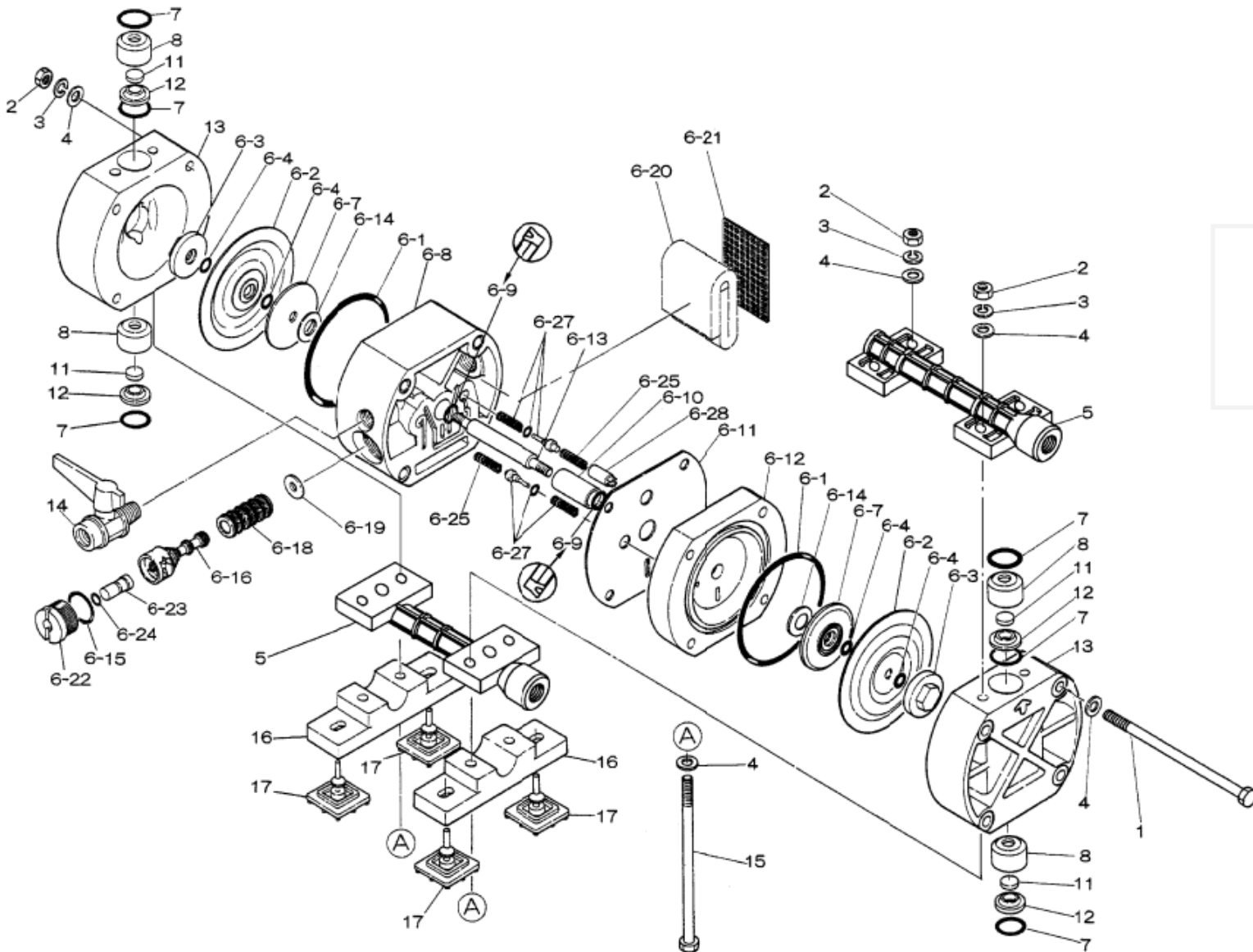

Tighting torque for:

Center rod: 7,5Nm
 Out chamber: 7,5Nm
 Manifold: 7,5Nm

Special tools (sold seperately)

771132 Cap and disk remover
 713148 Sleeve remover

Miscellaneous:

Assembly oil;
 use turbine oil none additional class 1
 Equiv. to ISO VGA32 grade
 Use Urea grease grade NLGI No. 2

EXPLODED VIEW & PARTS LISTING

Model : NDP-5FDT

Yamada Europe B.V.



Air Operated Double Diaphragm pump

Material : POM (Conductive Polyacetal)



MODEL : NDP-5FDT

Design #: 853779

REF. No.	DESCRIPTION	Q'TY.	Part No.	
1	BOLT	4	682748	
2	NUT	8	687229	
3	SPRING WASHER	8	681855	
4	PLAIN WASHER	16	631328	
5	MANIFOLD	2	780198	
6	BODY ASSY	1	804391	
6- 1	O RING	2	640139	
6- 2	DIAPHRAGM	2	771093	
6- 3	CENTER DISK	2	772721	
6- 4	O RING	4	643003	
6- 7	CENTER DISK	2	709317	
6- 8	BODY (L)	1	780000	
6- 9	PACKING	2	685752	
6-10	BUSHING	1	771088	
6-11	GASKET	1	771980	
6-12	BODY (S)	1	780001	
6-13	CENTER ROD	1	709316	
6-14	CUSHION	2	771239	
6-15	O RING	1	640017	
6-16	C SPOOL ASSY	1	802386	
* O-ringen	6-18	SLEEVE ASSY	1	803214
	6-19	CUSHION	1	771096
	6-20	MUFFLER FELT	1	771465
	6-21	MESH	1	771589
	6-22	CAP	1	771100
	6-23	RESET BUTTON	1	771099
	6-24	O RING	1	640002
	6-25	SPRING	2	709319
	6-27	PILOT VALVE ASSY	2	803510
* gasket P.V.A.	6-28	STOPPER	1	771095
	7	O RING	6	643015
	8	VALVE STOPPER	4	772712
	11	FLAT VALVE	4	771094
	12	VALVE SEAT	4	772736
	13	OUT CHAMBER	2	780233
	14	VALVE	1	686825
	15	BOLT	4	682747
	16	BASE	2	772715
	17	RUBBER FOOT	4	771102
	KIT	DIAPHRAGM		K5D-PT
	KIT	VALVE		K5V-DT
	KIT	WET END REPAIR		K5-PT-2
	KIT	AIR MOTOR		K5-AM
	KIT	AIR MOTOR SEAL		K5-AMS

Special tools sold separately:

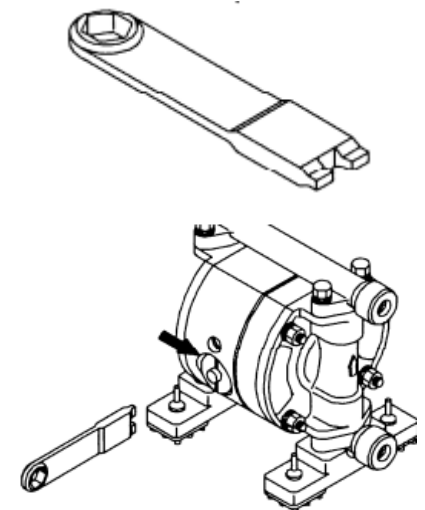

771132—Cap and Disk remover

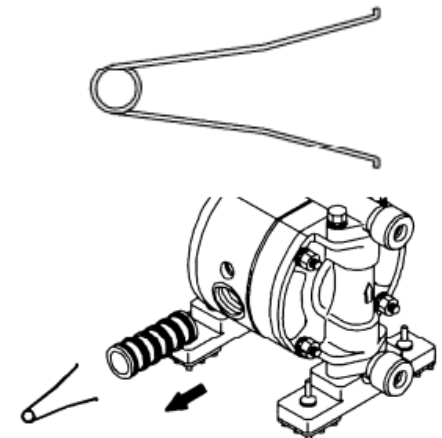

713148—Sleeve remover

EXPLODED VIEW & PARTS LISTING

Air Operated Double Diaphragm pump



Model : NDP-5FDT

Yamada Europe B.V.



Material : POM (Conductive Polyacetal)

Diaphragm options	PTFE
Max performance	11 L/min
Manifold connection	1/4" Rc
Net Weight	1,7 kg

MODEL : NDP-5FDT

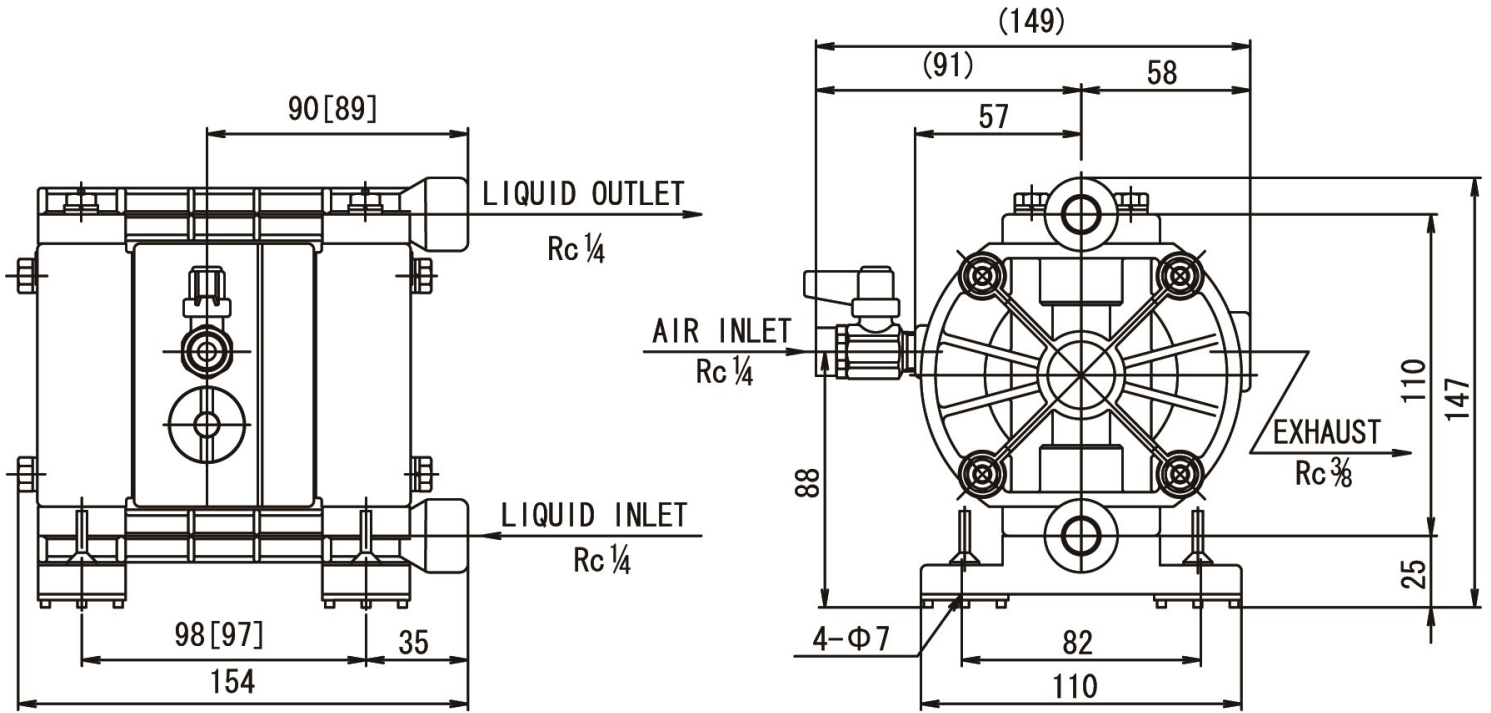

0,1MPa = 1Bar

