

EXPLODED VIEW & PARTS LISTING

Air Operated Double Diaphragm pump

Model : NDP-80BF.

Material: Cast Iron (FC250)

Yamada Europe B.V.



To Purchase:

More information:

☎ 0031 (0)74 242 2032

▶ YouTube: [@yamadapump](https://www.youtube.com/@yamadapump)

✉ sales@yamada.nl

🌐 yamada-europe.com

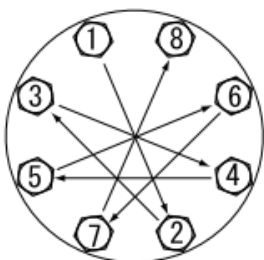
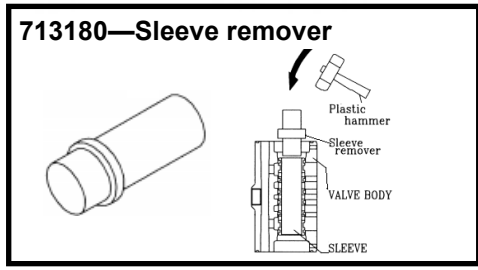
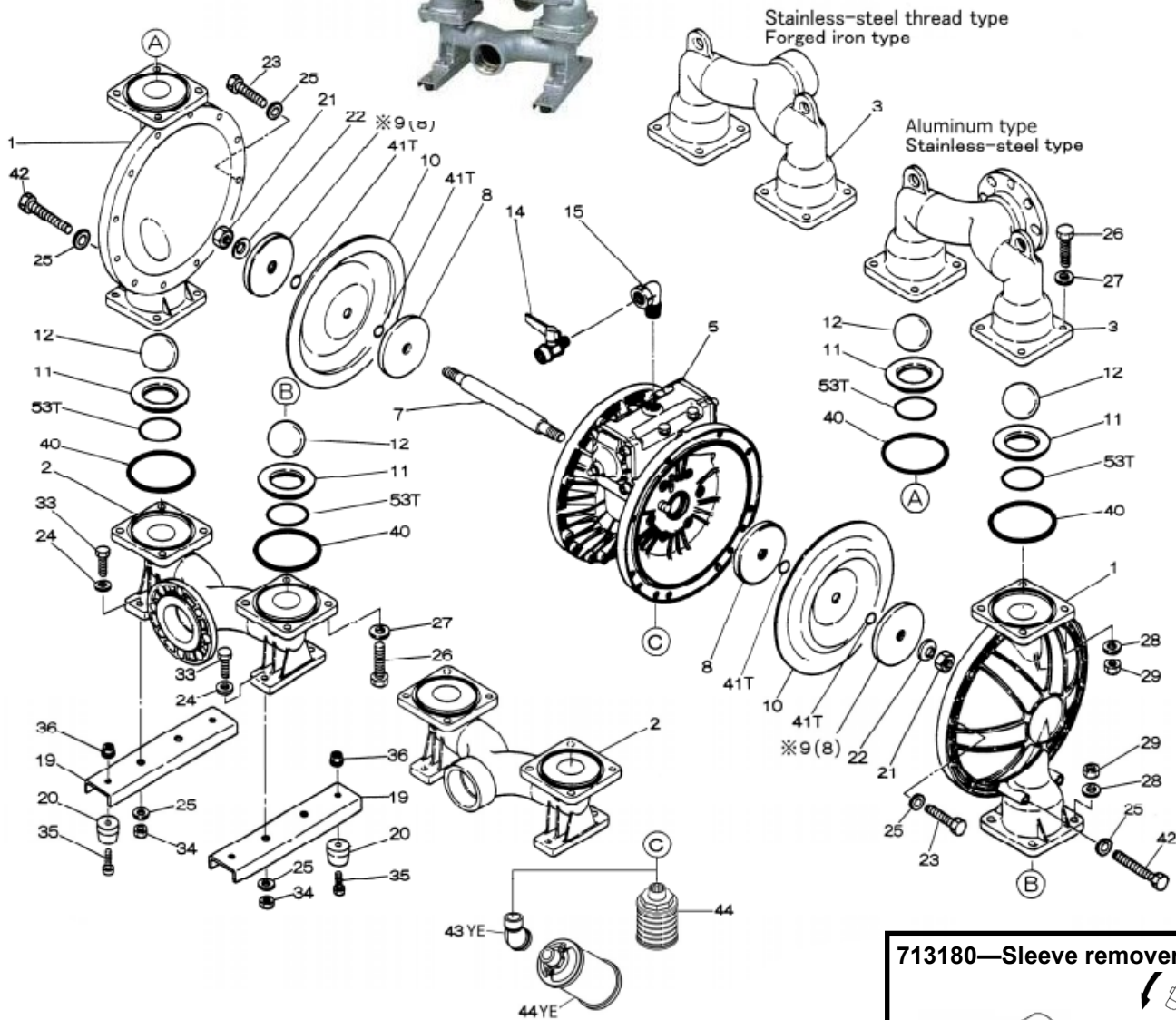

Tighting torque for:

Center rod:	60 Nm
Center rod TU:	Hand tight
Out chamber:	40 Nm
Manifold:	25 Nm

Special tools (sold seperately)

713180 Sleeve remover

Miscellaneous:

Assembly oil: use turbine oil none additional class 1
 Equiv. to ISO VGA32 grade
 Use Urea grease grade NLGI No. 2



Body Assembly

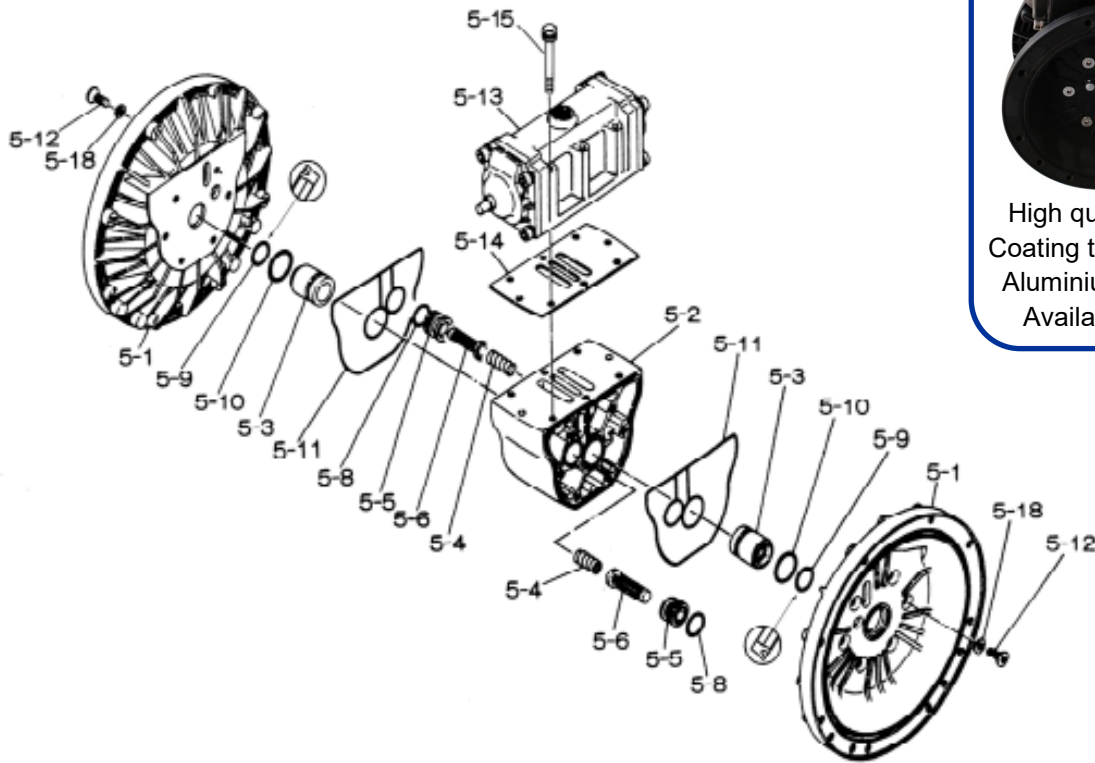

Valve Body Assembly

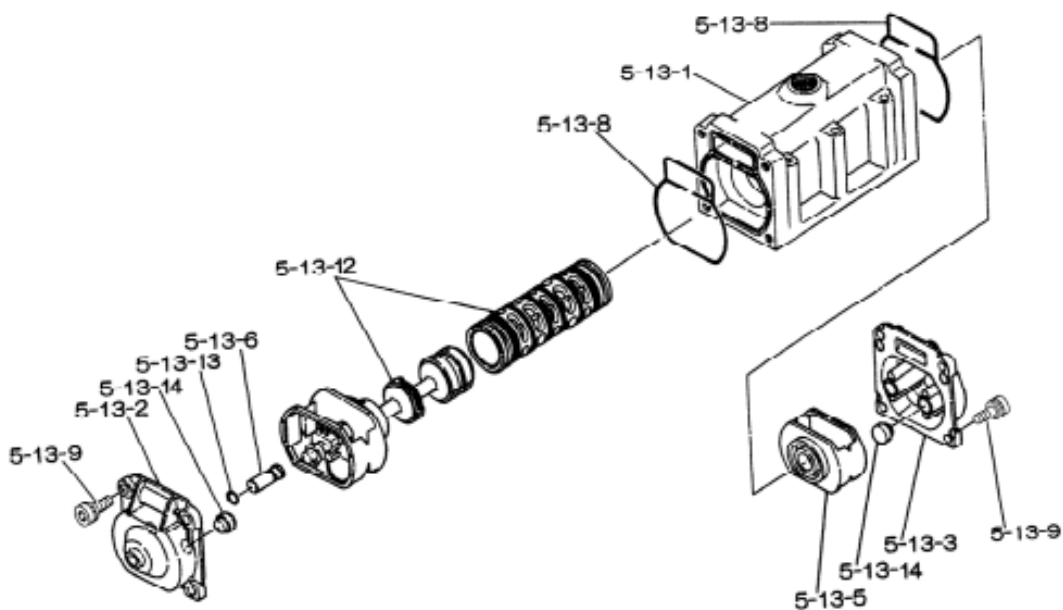

EXPLODED VIEW & PARTS LISTING

Model : NDP-80BF.

Yamada Europe B.V.



Air Operated Double Diaphragm pump

Material: Cast Iron (FC250)



Diaphragm

Design #

REF.No.	DESCRIPTION	Q-TY.	CR	NBR	EPDM	TPEE	TPO	FPM	PTFE	PTFE-EPDM
			BFC	BFN	BFE	BFH	BFS	BFV	BFT	BFTU
			855097	855098	855099	855102	855103	855100	855101	YE original
Part No.	Part No.	Part No.	Part No.	Part No.	Part No.	Part No.	Part No.	Part No.	Part No.	
1	OUT CHAMBER	2	713158	713158	713158	713158	713158	713158	713158	713158
2	IN MANIFOLD (FLANGE RC)	1	713164	713164	713164	713164	713164	713164	713164	713164
3	OUT MANIFOLD (FLANGE RC)	1	713161	713161	713161	713161	713161	713161	713161	713161
5	BODY ASSY	1	803123	803123	803123	803123	803123	803123	803123	803123
5- 1	AIR CHAMBER	2	711935	711935	711935	711935	711935	711935	711935	711935
5- 2	BODY	1	711947	711947	711947	711947	711947	711947	711947	711947
*5- 3	THROAT BEARING	2	772689	772689	772689	772689	772689	772689	772689	772689
5- 4	SPRING	2	711937	711937	711937	711937	711937	711937	711937	711937
5- 5	VALVE SEAT	2	771740	771740	771740	771740	771740	771740	771740	771740
5- 6	PILOT VALVE ASSY	2	832163	832163	832163	832163	832163	832163	832163	832163
5- 8	O RING	2	640020	640020	640020	640020	640020	640020	640020	640020
5- 9	PACKING	2	685444	685444	685444	685444	685444	685444	685444	685444
5-10	O RING	2	640029	640029	640029	640029	640029	640029	640029	640029
5-11	GASKET	2	771742	771742	771742	771742	771742	771742	771742	771742
5-12	BOLT	12	683812	683812	683812	683812	683812	683812	683812	683812
5-13	VALVE BODY ASSY	1	803120	803120	803120	803120	803120	803120	803120	803120
5-13- 1	VALVE BODY	1	711946	711946	711946	711946	711946	711946	711946	711946
5-13- 2	CAP A	1	580999	580999	580999	580999	580999	580999	580999	580999
5-13- 3	CAP B	1	581000	581000	581000	581000	581000	581000	581000	581000
5-13- 5	SPRING RETAINER	1	771735	771735	771735	771735	771735	771735	771735	771735
5-13- 6	RESET BUTTON	1	712976	712976	712976	712976	712976	712976	712976	712976
5-13- 8	GASKET	2	771738	771738	771738	771738	771738	771738	771738	771738
5-13- 9	BOLT	8	685036	685036	685036	685036	685036	685036	685036	685036
5-13-12	C SPOOL ASSY	1	805084	805084	805084	805084	805084	805084	805084	805084
5-13-13	O RING	1	640005	640005	640005	640005	640005	640005	640005	640005
5-13-14	CUSHION	4	684128	684128	684128	684128	684128	684128	684128	684128
5-14	GASKET	1	771712	771712	771712	771712	771712	771712	771712	771712
5-15	BOLT & WASHER	6	684240	684240	684240	684240	684240	684240	684240	684240
5-18	PLAIN WASHER	12	684987	684987	684987	684987	684987	684987	684987	684987
7	CENTER ROD	1	711901	711901	711901	711901	711901	711901	711940	717131
8	CENTER DISK	2	711906	711906	711906	711906	711906	711906	711041	-
9	CENTER DISK	2	713371	713371	713371	713371	713371	713371	713391	-
10	DIAPHRAGM	2	771857	771704	771858	771705	771977	771801	770934	833231
11	VALVE SEAT	4	771958	771996	771999	771795	772005	771998	711910	711910
12	BALL	4	770559	770587	770596	773144	773174	770605	770694	770694
14	VALVE	1	686973	686973	686973	686973	686973	686973	686973	686973
15	ELBOW	1	634034	634034	634034	634034	634034	634034	634034	634034
19	BASE	2	711912	711912	711912	711912	711912	711912	711912	711912
20	RUBBER FOOT	4	771402	771402	771402	771402	771402	771402	771402	771402
21	NUT	2	683408	683408	683408	683408	683408	706144	706144	-
22	CONED DISC SPRING	2	682740	682740	682740	682740	682740	682740	682740	-
23	BOLT	20	686161	686161	686161	686161	686161	686161	686161	686024
24	PLAIN WASHER	4	631014	631014	631014	631014	631014	631014	631014	631014
25	WAVE WASHER	28	631917	631917	631917	631917	631917	631917	631917	631917
26	BOLT	16	611204	611204	611204	611204	611204	611204	611204	611204
27	PLAIN WASHER	16	631015	631015	631015	631015	631015	631015	631015	631015
28	WAVE WASHER	16	631918	631918	631918	631918	631918	631918	631918	631918
29	NUT	16	627014	627014	627014	627014	627014	627014	627014	627014
33	BOLT	4	611177	611177	611177	611177	611177	611177	611177	611177
34	NUT	4	627013	627013	627013	627013	627013	627013	627013	627013
35	BOLT	4	611149	611149	611149	611149	611149	611149	611149	611149
36	FLANGED NUT	4	682276	682276	682276	682276	682276	682276	682276	682276
40	O RING	4	640078	640078	684124	640078	684124	642078	643078	643078
41T	O RING	4	-	-	-	-	-	-	643015	-
42	BOLT	4	686164	686164	686164	686164	686164	686164	686164	686026
43YE	ELBOW	1	634050	634050	634050	634050	634050	634050	634050	634050
44YE	MUFFLER	1	687235	687235	687235	687235	687235	687235	687235	687235
53T	O RING	4	-	-	-	-	-	-	643145	643145
KIT	DIAPHRAGM		K80D-MC	K80D-MN	K80D-ME	K80D-MH	K80D-MS	K80D-MV	K80D-MT	K80D-TU
KIT	VALVE		K80V-MC	K80V-MN	K80V-ME	K80V-MH	K80V-MS	K80V-MV	K80V-ST	K80V-TU
KIT	WET END REPAIR		K80-MC	K80-MN	K80-ME	K80-MH	K80-MS	K80-MV	K80-MT	K80-TU
KIT	AIR MOTOR									
KIT	AIR MOTOR SEAL									

! * Throat bearing position 5-3, 772689 is only available as an assembly. Positions 5-3, 5-9 and 5-10. Article code 020689

EXPLODED VIEW & PARTS LISTING

Air Operated Double Diaphragm pump



Model : NDP-80BF.

Yamada Europe B.V.



Material: Cast Iron (FC250)

Diaphragm options	CR, EPDM, NBR, FPM, TPEE, TPO	PTFE	TU
Max performance	840 L/min	640 L/min	830 L/min
Manifold connection	Rc 3"		
Net Weight	110,0 kg		

MODEL : NDP-80BF.

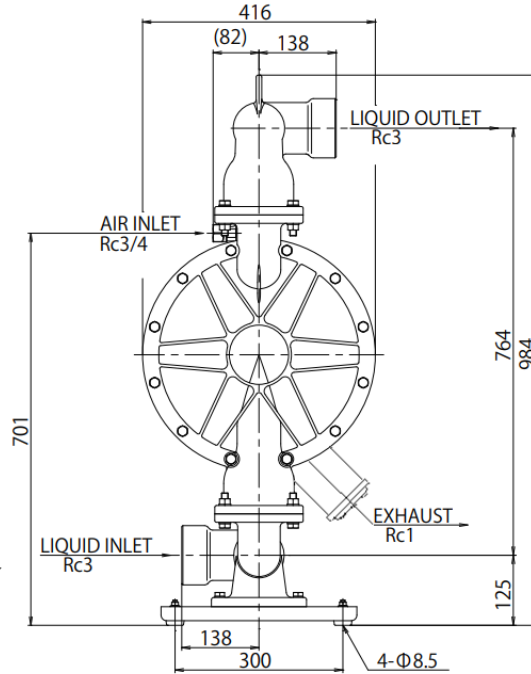
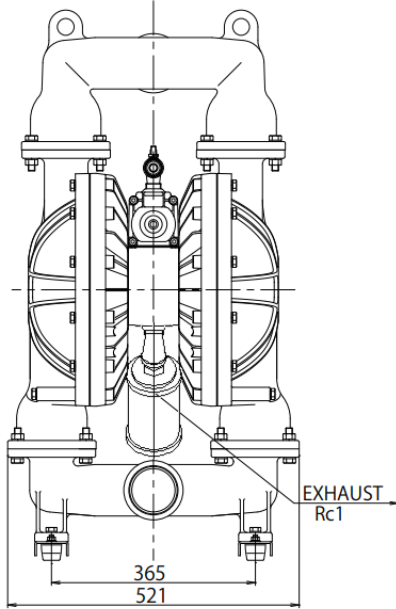

NDP-80BA □, BS □, BF □

0,1MPa = 1Bar

NDP-80BAT, BST, BFT

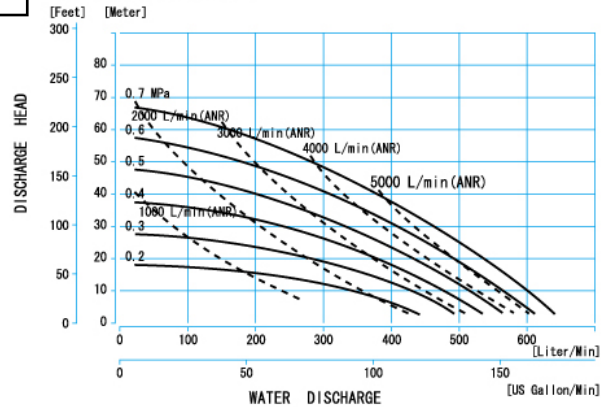
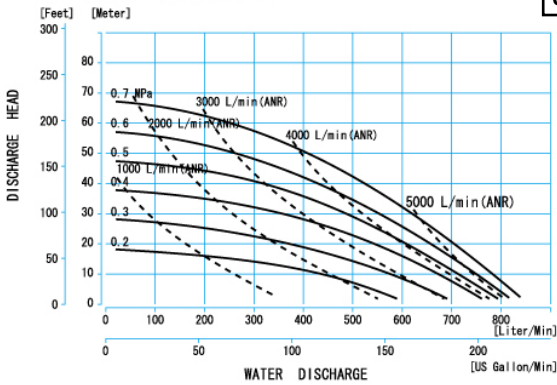

NDP-40BATU, BFTU, BSTU

