

EXPLODED VIEW & PARTS LISTING

Air Operated Double Diaphragm pump

Model : NDP-15BA.

Yamada Europe B.V.



Material: Aluminium (ADC12)

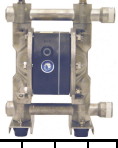

DIAPHRAGM

Design #

REF. No.	DESCRIPTION	Q'TY.	Material						
			CR	NBR	HYTREL	SANTOPRENE	PTFE	PTFE-EPDM	
			BAC	BAN	BAH	BAS	BAT	BATU	
			851946	851947	851948	852680	851945	YE Original	
Part No.	Part No.	Part No.	Part No.	Part No.	Part No.	Part No.	Part No.		
1	BOLT	6	687054	687054	687054	687054	687054	687054	
2	PLAIN WASHER	12	631209	631209	631209	631209	631209	631209	
3	SPRING WASHER	6	631420	631420	631420	631420	631420	631420	
4	NUT	6	687229	687229	687229	687229	687229	687229	
5	O RING	4	640025	640025	640025	684114	643025	643025	
6	BALL GUIDE	4	771523	771523	771523	771523	771523	771523	
7	BALL	4	771526	771525	773125	773169	771524	771524	
8	VALVE SEAT	4	711227	711227	711227	711227	711227	711227	
9	OUT CHAMBER	2	711226	711226	711226	711226	711226	711226	
10	MANIFOLD ASSY	2	802707	802707	802707	802707	802707	802707	
11	VALVE	1	686825	686825	686825	686825	686825	686825	
12	FLANGED NUT	4	682817	682817	682817	682817	682817	682817	
13	BOLT	4	611101	611101	611101	611101	611101	611101	
14	BASE	2	717185	717185	717185	717185	717185	717185	
15	O RING	4	640130	640130	640130	684113	643130	643130	
16	BODY ASSY	1	802993	802994	802995	803502	802992	802994	
16-1	DIAPHRAGM	2	770971	770973	771372	771972	770933	833027	
16-2	O RING	2	640144	640144	640144	640144	640144	640144	
16-3	O RING	2	640020	640020	640020	640020	640020	640020	
16-4	PACKING	2	684284	684284	684284	684284	684284	684284	
16-5	GUIDE	1	771337	771337	771337	771337	771337	771337	
16-6	CENTER ROD	1	710578	710578	710578	710578	710578	716573	
16-7	BUSHING	2	771336	771336	771336	771336	771336	771336	
16-8	O RING	4	640005	640005	—	—	643005	—	
16-9	CENTER DISK	2	708770	708770	708770	708770	708770	—	
16-10	NUT	2	681849	681849	681849	681849	681849	—	
16-11	CONED DISC SPRING	2	684916	684916	684916	684916	684916	—	
16-12	BODY A	1	780028	780028	780028	780028	780028	780028	
16-13	GASKET	1	771347	771347	771347	771347	771347	771347	
16-14	BODY B	1	780030	780030	780030	780030	780030	780030	
16-15	CUSHION	2	771342	771342	771342	771342	771342	771342	
16-16	CENTER DISK	2	771344	771344	771344	771344	771344	020109	
16-17	CUSHION	1	771483	771483	771483	771483	771483	771483	
O-rings sleeve	16-18	SLEEVE ASSY	1	804249	804249	804249	804249	804249	804249
16-19	C SPOOL ASSY	1	802835	802835	802835	802835	802835	802835	
16-20	CAP	1	771695	771695	771695	771695	771695	771695	
16-21	O RING	1	640022	640022	640022	640022	640022	640022	
16-22	RESET BUTTON	1	771350	771350	771350	771350	771350	771350	
16-23	O RING	1	640002	640002	640002	640002	640002	640002	
16-24	MESH	2	771589	771589	771589	771589	771589	771589	
16-25	MUFFLER FELT	1	771465	771465	771465	771465	771465	771465	
16-26	PILOT VALVE ASSY	2	832141	832141	832141	832141	832141	832141	
16-28	SPRING	2	710577	710577	710577	710577	710577	710577	
16-29	SPRING PIN	2	632752	632752	632752	632752	632752	632752	
17	BOLT & WASHER	8	686359	686359	686359	686359	686359	686359	
18	RUBBER FOOT	4	771123	771123	771123	771123	771123	771123	
KIT	DIAPHRAGM		K15D-MC	K15D-MN	K15D-MH	K15D-MS	K15D-MT	K15D-MTU	
KIT	VALVE		K15V-AC	K15V-AN	K15V-AH	K15V-AS	K15V-AT	K15V-AU	
KIT	WET END REPAIR		K15-MC	K15-MN	K15-MH	K15-MS	K15-MT	K15-MTU	
KIT	AIR MOTOR		K10/15-AM						
KIT	AIR MOTOR SEAL		K10/15-AMS						

EXPLODED VIEW & PARTS LISTING

Air Operated Double Diaphragm pump

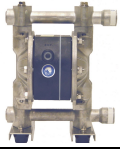

MODEL : NDP-15BA.

Model : NDP-15BA.

Yamada Europe B.V.



Material: Aluminium (ADC12)

Diaphragm options	CR, NBR, TPEE, TPO	PTFE	TU
Max performance	50 L/min	45 L/min	42 L/min
Manifold connection	Rc 1/2"		
Net Weight	4,0 kg		

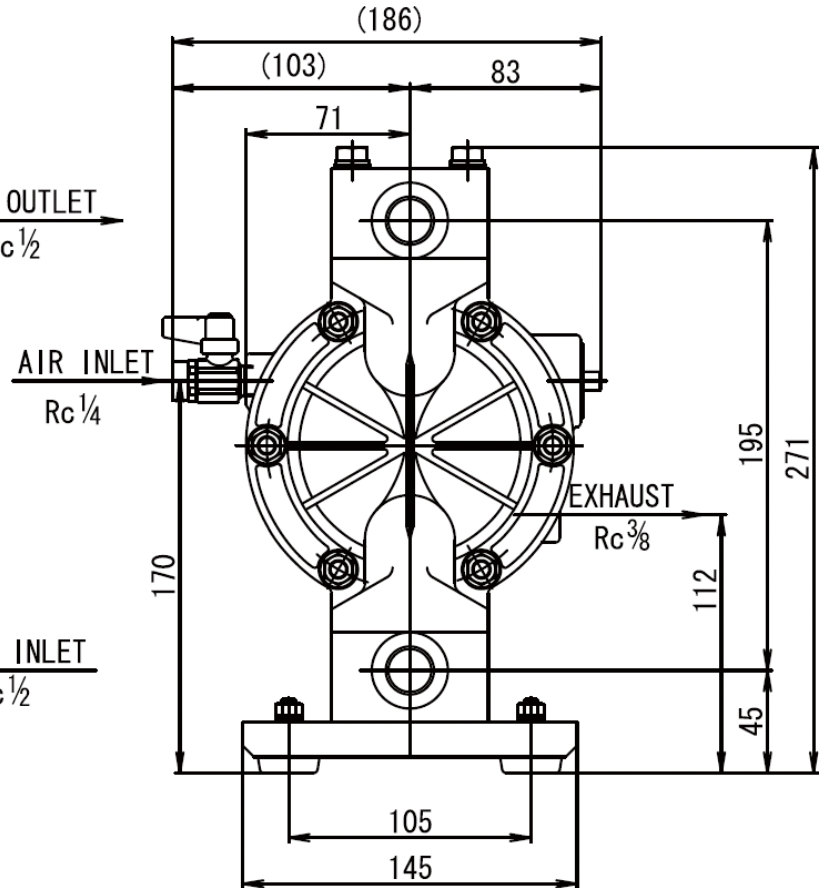
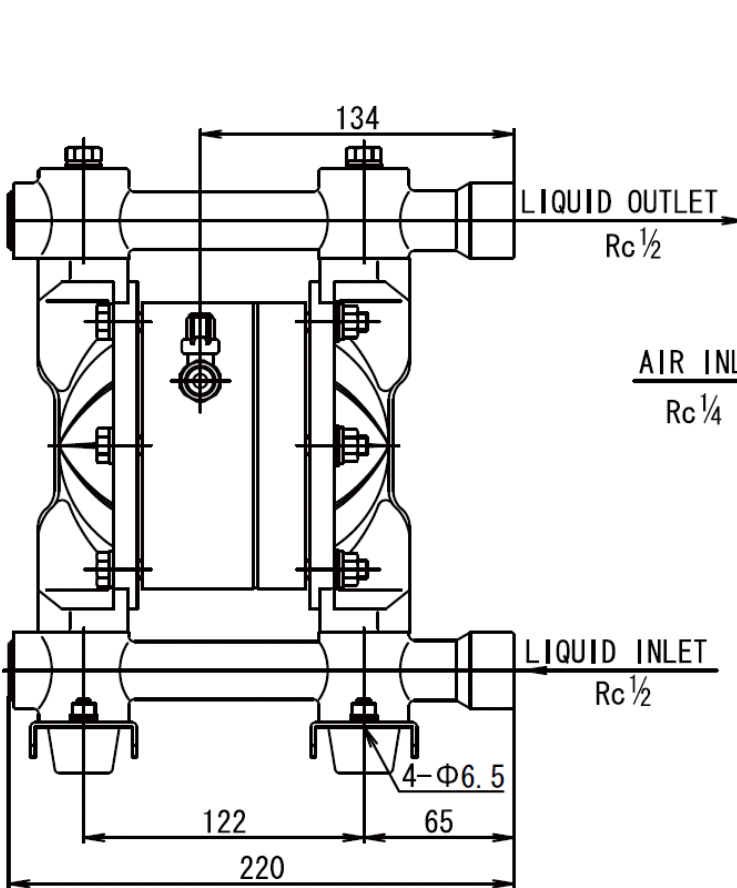

0,1MPa = 1Bar

NDP-15BA □ · 15BS □

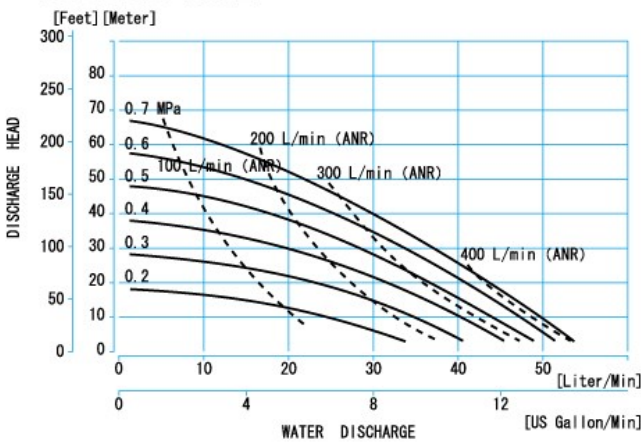

NDP-15BATU

